

**tedisel**medical

# COLUMN

## INSTALLATION MANUAL



[tediselmedical.com](http://tediselmedical.com)

# Content

1.	Manufacturer.....	5
2.	Security information.....	5
2.1.	Injury risk warnings.....	5
2.2.	Warnings of risk of damage .....	5
2.3.	Additional symbols used in the safety instructions.....	6
2.4.	Indication of additional information.....	6
2.5.	Proper use of oxygen.....	6
2.5.1.	Oxygen explosion.....	6
2.5.2.	Fire hazard .....	6
2.6.	Patient environment.....	7
2.7.	Combination with products from other manufacturers.....	7
3.	Risks.....	8
3.1.	Gas explosion .....	8
3.2.	Risk of device malfunction .....	8
3.3.	Risk of patient contamination and infection.....	8
3.4.	Fire risk.....	8
3.5.	Danger of electric shock.....	8
3.6.	Risk of collision .....	9
3.7.	Risk of system crash due to overload .....	9
3.8.	Risk of system crash due to poor installation .....	9
4.	Symbols used .....	9
5.	Installation requirements .....	12
5.1.	Equipment required for installation .....	12
5.2.	Training .....	12
6.	Installation and connection .....	13
6.1.	Installation references.....	13
6.2.	Installation references. Accessories. Lighting, indicators.....	32
6.3.	Additional instructions.....	36
6.4.	Loading data.....	36
6.4.1.	COLUMN ROTATION .....	37
6.4.2.	COLUMN AIR.....	37
6.4.3.	COLUMN AIRPLUS AND COLUMN FRICTION .....	38

6.4.4.	COLUMN AND COLUMN INVERTED .....	39
6.4.5.	COLUMN XL .....	39
6.4.6.	COLUMN XXL .....	41
6.4.7.	COLUMN MOTOR, COLUMN MOTOR XL, COLUMN MOTOR XXL .....	42
6.4.8.	COLUMN MOTOR AIRPLUS, COLUMN MOTOR FRICTION .....	43
6.4.9.	COLUMN SPRING AIRPLUS, COLUMN SPRING FRICTION .....	43
6.4.10.	COLUMN SPRING E-BRAKE .....	44
6.4.11.	Service head and accessories .....	44
6.5.	Mounting of threaded bolts on the interface plate .....	45
6.5.1.	Installation without false ceiling .....	45
6.5.2.	Mounting with false ceiling .....	47
6.5.3.	Mounting of interface plate on the false ceiling bracket .....	50
6.6.	Pre-assembly: Ceiling tube (included), drop arm and drop tube .....	52
6.6.1.	Description of components .....	52
6.6.2.	Ceiling tube mounting .....	56
6.6.3.	Mounting the tension release mechanism on the ceiling tube .....	58
6.6.4.	Mounting of the roof tube earthing cable .....	59
6.6.5.	Mounting of the arm on the threaded bolts of the interface plate .....	60
6.6.6.	Alignment of the arms with the Interface plate .....	62
6.6.7.	Assembly of the drop tube on the arms .....	63
6.6.8.	Installation of the arm lighting (retrofitting only) .....	65
6.6.9.	Fitting of brake indicators (retrofitting only) .....	66
6.7.	Service head assembly .....	67
6.8.	Cable / hose routing .....	70
6.8.1.	Connection of pneumatic brakes .....	71
6.8.2.	Connection of supply and management circuits for electromagnetic or motor brakes	73
6.8.3.	Connection of the earthing cables to the support arm .....	74
6.8.4.	Laying of power cables and hoses through the support arm .....	75
6.8.5.	Installation of gas hoses and air exhaust ducts .....	76
6.8.6.	Connection of the different electrical circuits .....	78
6.8.7.	Extension arm lighting connection (optional) .....	79
6.9.	Fitting of trims .....	80
6.9.1.	Fitting of a single / double trim .....	80
6.9.2.	Fitting of protective covers. Covers .....	81
6.9.2.1.	Assembly/disassembly of protective caps on an extension arm .....	81

6.9.2.2.	Mounting of rear and front covers on a motor or spring arm.....	82
6.9.2.3.	Mounting of rear side covers on a motor or spring arm .....	83
6.9.2.4.	Rear bottom cover mounting on a motor or spring arm.....	84
6.9.2.5.	Mounting of front side covers on a motor or spring arm .....	85
6.9.2.6.	Mounting of front top cover on a motor or spring arm .....	86
6.10.	Adjustments .....	87
6.10.1.	Adjustment of the mechanical brake on the arms .....	87
6.10.2.	Adjustment of the mechanical brake on the drop tube (with bearing).....	89
6.10.3.	Adjustment of the mechanical brake on the drop tube (with bearing).....	89
6.10.4.	Adjustment of the rotary stops .....	90
6.10.5.	Replacement or disassembly of the rotary stops .....	93
6.10.6.	Assembly of the rotary stops.....	94
6.10.7.	Vertical lift adjustment on the motor arm .....	95
6.10.7.1.	Opening / closing of the lower rear cover .....	96
6.10.8.	Correcting the vertical alignment of the Service Head on a power arm.....	97
6.10.9.	Vertical alignment correction of the CEMOR monitor bracket or Service Head on a spring-loaded arm .....	98
6.10.10.	Adjusting the load capacity on the spring arm .....	99
6.10.10.1.	Opening / closing of the lower rear cover .....	100
6.10.11.	Adjusting vertical lift on a spring arm .....	101
6.10.11.1.	Opening/closing of the front top cover .....	102
7.	Installation checks.....	103
7.1.	Check the technical characteristics of the equipment to be installed. Weights, torques. ....	103
7.2.	Check the condition of the cables and hoses in the system and the rotation of the arms. ....	104
7.1.	Mechanical test .....	105
7.2.	Check the service head enclosure. ....	105
7.3.	Mechanical crash test .....	105
7.4.	Gas circuit test.....	105
7.5.	Electrical circuit tests. ....	106
8.	Regulations .....	106
8.1.	Team ranking.....	106
8.2.	Reference standards.....	106



## 1. Manufacturer

Manufacturer: TEDISEL IBÉRICA S.L.

Address: C/ Sant Lluc, 69-81. 08918 - Badalona (Barcelona) SPAIN

Tel. +34 933 992 058

Fax +34 933 984 547

tedisel@tedisel.com

[www.tediselmedical.com](http://www.tediselmedical.com)



## 2. Security information

Important notes in these operating instructions are marked with graphic symbols and signal words.

### 2.1. Injury risk warnings

Signal words such as DANGER, WARNING or CAUTION describe the degree of risk of injury. The different triangular symbols visually emphasise the degree of danger.



WARNING

Refers to a potentially hazardous situation which, if not avoided, could result in death or serious injury.



CAUTION

Refers to a potential hazard which, if not avoided, may result in minor or slight injury.



DANGER

Refers to an immediate danger which, if not avoided, will result in death or serious injury.



Risk of finger entrapment

### 2.2. Warnings of risk of damage

The signal word WARNING describes the degree of risk of material damage. The triangular symbol visually emphasises the degree of danger.



Damage to surfaces: warns of damage to surfaces due to unsuitable cleaning agents and disinfectants.



NOTICE

Refers to a potential hazard which, if not avoided, may cause damage to the equipment.

### 2.3. Additional symbols used in the safety instructions



Fire hazard



Explosion hazard: warns of ignition of explosive gas mixtures.



Dangerous voltage: warns about electric shocks that can cause serious injury or death.



Failure of the roof support system



Risk of collision

### 2.4. Indication of additional information

NOTA

A NOTE provides additional information and useful tips for safe and efficient use of the device.

### 2.5. Proper use of oxygen.

#### 2.5.1. Oxygen explosion



Oxygen becomes explosive when it comes into contact with oils, greases and lubricants.

Compressed oxygen presents an explosion hazard:

- Make sure that oxygen and gas outlets are free of oil, greasy materials and lubricants!
- Do not use cleaning agents containing oil, grease or lubricants.

#### 2.5.2. fire hazard



**DANGER:** Escaping oxygen is combustible:

- Open fire, red-hot objects and open light are not allowed when working with oxygen!
- Don't smoke!

## 2.6. Patient environment

The dimensions in the figure below illustrate the minimum extent of the patient environment in an unrestricted area according to IEC 60601-1.

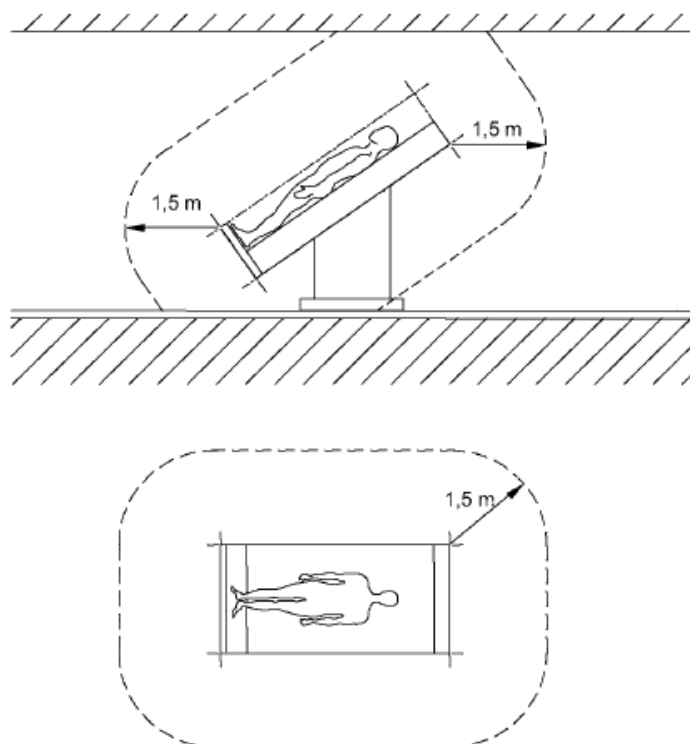

Fig. 1 Minimum extent of the PATIENT ENVIRONMENT

## 2.7. Combination with products from other manufacturers.

The suspension system is combined with the service head. To avoid dangerous overloads, which can damage or cause collapse of the service head and the pendant system, the specified maximum load capacity must be observed.



See point 6.7 of the user and cleaning manual supplied with the equipment.

Power supply packages intended to supply power to end devices must ensure electrical isolation and provide two protective measures according to IEC 60601-1.

NOTA

The party putting the device into operation is responsible for the validation of the whole system. If necessary, a conformity assessment procedure shall be performed and a declaration of conformity with Article 22 of the Medical Devices Regulation (EU) 2017/745 shall be provided.



Read the Operating Instructions provided by the external manufacturer to obtain the necessary information for the operation of the end device.

### 3. Risks

#### 3.1. Gas explosion



Oxygen becomes explosive when it comes into contact with oils, greases and lubricants.

When in contact with oxygen in the air, medical gases may form an explosive or easily flammable gas mixture. The equipment is not suitable for use in environments containing flammable mixtures of anaesthetics with high concentrations of oxygen or nitrous oxide.

If such high concentrations of flammable mixtures of anaesthetics with oxygen or nitrous oxide occur in the environment of the device, there is a risk of ignition under certain conditions.

#### 3.2. Risk of device malfunction



CAUTION: If a device is connected to the equipment and trips the protection mechanism of the corresponding circuit in the health care facility, other devices connected to the equipment will not receive power.

#### 3.3. Risk of patient contamination and infection



WARNING: Parts of the pendant system and adaptations are made of plastic. Solvents can dissolve plastic materials. Strong acids, bases and agents with an alcohol content of more than 60 % can cause plastic materials to become brittle. Dislodged particles may fall into open wounds. If liquid cleaning agents are allowed to penetrate the suspension system and adaptations, excess cleaning fluid may drip into open wounds.

#### 3.4. Fire risk



Plug-in connections for the supply of medical gases must not come into contact with oil, grease or flammable liquids.

#### 3.5. Danger of electric shock



Signal cables (network, audio, video, etc.) must be electrically isolated from equipment and the ends of building connections to prevent contact with currents that can cause serious injury or death.

### 3.6. Risk of collision



In the event of a collision with other devices, walls or ceilings, the pendant system and service head may be damaged and important patient care systems may fail, after a collision, the service head and pendant system should be inspected for damage.

### 3.7. Risk of system crash due to overload



The dead weights of all attached components and the weight of the attached loads must not exceed the maximum load weight of the base support unit.



If the maximum load capacity has been exceeded, there is a risk that the suspension system or components of the suspension system may become detached from the securing device and fall.

- The maximum load capacity of the suspension system and its components must not be exceeded!



See point 6 of the user and cleaning manual supplied with the equipment.

- Do not attach or mount any additional loads on the extension arms, service head and end devices.

### 3.8. Risk of system crash due to poor installation



If the fasteners of the individual parts of the system are not correctly positioned or if the tightening torques of the fasteners are not observed, the suspension system may come loose from its fastenings and fall down.

## 4. Symbols used



Applicable part B



Earth (mass)



Equipotentiality



Protective earth (ground)

**N**

Connection point for neutral conductor



Nurse call button



Direct lighting



Indirect lighting



Operating instructions



Health Product



Waste electrical equipment



CE symbol



Product code



Unique identification code



Serial number



Manufacturer



Date of manufacture



Reference to the instruction manual



Damage to surfaces



Fire hazard



Danger of explosion



Dangerous tension



NOTICE

Notice



Risk of finger entrapment



WARNING

Warning



CAUTION

Caution



DANGER

Danger

## 5. Installation requirements

### 5.1. Equipment required for installation

- Lifting device or forklift with a permissible payload of at least 250 kg. Alternatively, a lifting winch with a permissible payload of at least 250 kg may be used if space is limited:



CAUTION

Check that the suspension system is sufficiently secured before lifting.



WARNING

During the lifting movement, be sure to avoid collisions with other suspension systems, devices, ceilings or walls and other assemblies.

- Protective gloves
- Digital spirit level
- Torque spanner
- Multimeter
- Standard tool kit
- Spanner 36
- 1 set of telescopic magnet pick-up tools
- Working platform (e.g. pedestal ladder) in accordance with country-specific occupational safety and health standards

### 5.2. Training

The personnel performing the installation must be properly trained and qualified by the customer. The equipment must only be INSTALLED by authorised personnel. Persons who:

1. Have received the training and are duly registered (at those levels where legal provisions make such registration necessary).
2. Have been instructed in the installation of this device by means of this instruction manual as a basis.
3. Are able to assess the tasks they perform on the basis of their own professional experience and training in relevant safety standards and can recognise the potential hazards involved in the work.



## 6. Installation and connection

### 6.1. Installation references

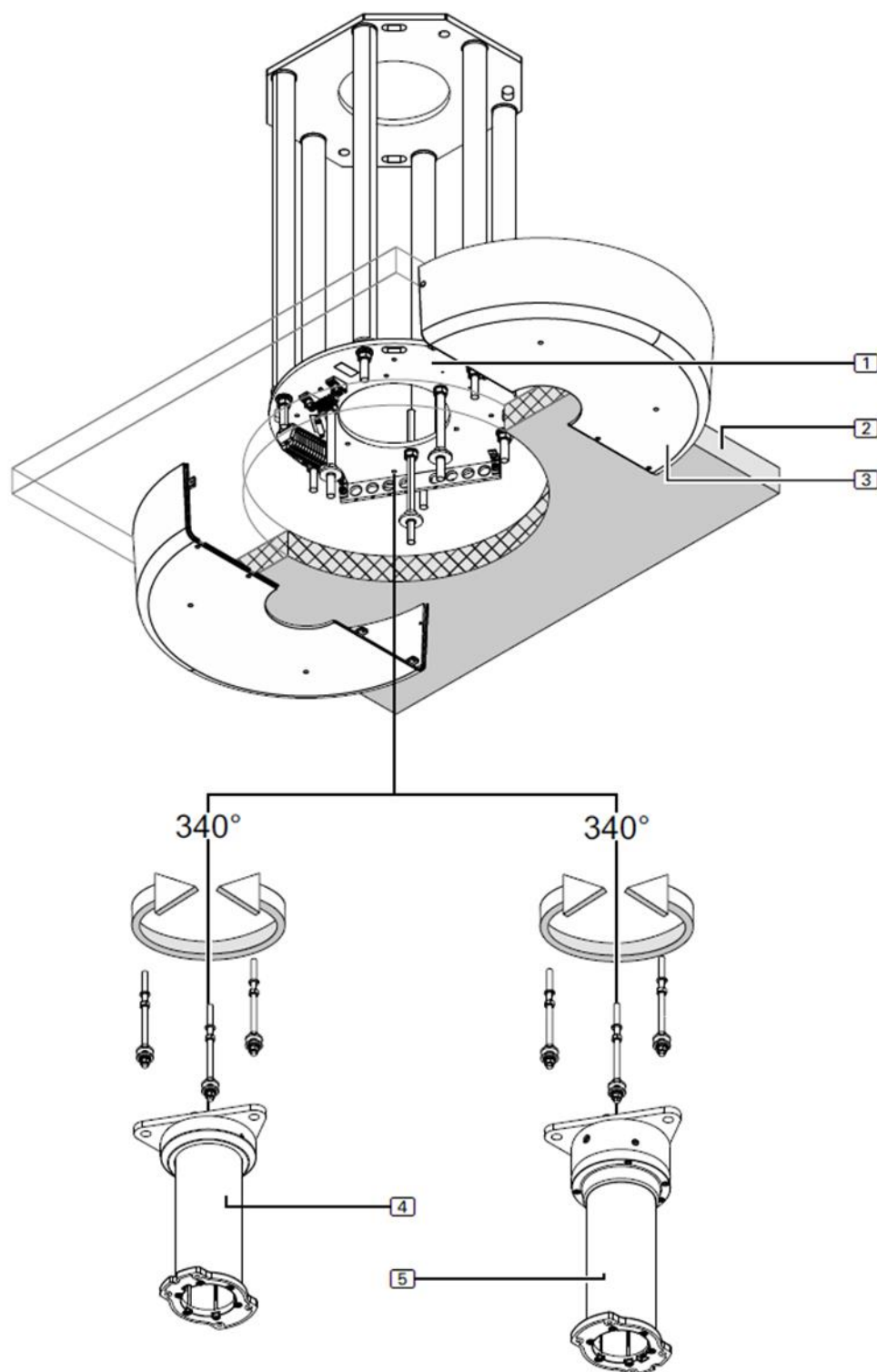





Fig. 2 COLUMN ROTATION

1	Interface board (Single / Double) - pre-assembled
2	False Ceiling (own installation)
3	Roof trim (depending on version)
	 See section 6.9.1 of this manual. Material included: <ul style="list-style-type: none"> <li>- 4 / 6 metal screws, 4 / 6 cover screws and 1 sectional strip</li> <li>- 4/6 threaded bolts M10 x 360mm, 4/6 hex nuts M10</li> </ul>
4	Drop tube - friction bearing variant CD.
	 See section 6.6.5 of this manual. Material included: <ul style="list-style-type: none"> <li>- 1 drop tube CD (length specified in the order)</li> <li>- 1 grounding cable, 4mm<sup>2</sup> 1 grounding cable, 4mm<sup>2</sup> 1 grounding cable, 4mm<sup>2</sup> 1 grounding cable, 4mm</li> <li>- 3 threaded rods M16 x 330mm</li> <li>- 9 hex nuts M16</li> <li>- 6 spring rings</li> <li>- 6 discs 40 x 50 x 4mm</li> <li>- 12 flat washers 34 mm outside diameter and 12 insulating discs</li> <li>- 6 insulating discs</li> </ul>
5	Drop tube - roller bearing variant RR.
	 See section 6.6.5 of this manual. Material included: <ul style="list-style-type: none"> <li>- 1 RR drop tube (length specified on order)</li> <li>- 1 grounding cable, 4mm<sup>2</sup> 1 grounding cable, 4mm<sup>2</sup> 1 grounding cable, 4mm<sup>2</sup> 1 grounding cable, 4mm</li> <li>- 3 threaded rods M16 x 330mm</li> <li>- 9 hex nuts M16</li> <li>- 6 spring rings</li> <li>- 6 discs 40 x 50 x 4mm</li> <li>- 12 flat washers of 34 mm outer diameter and 12 insulating discs</li> <li>- 6 insulating discs</li> </ul>

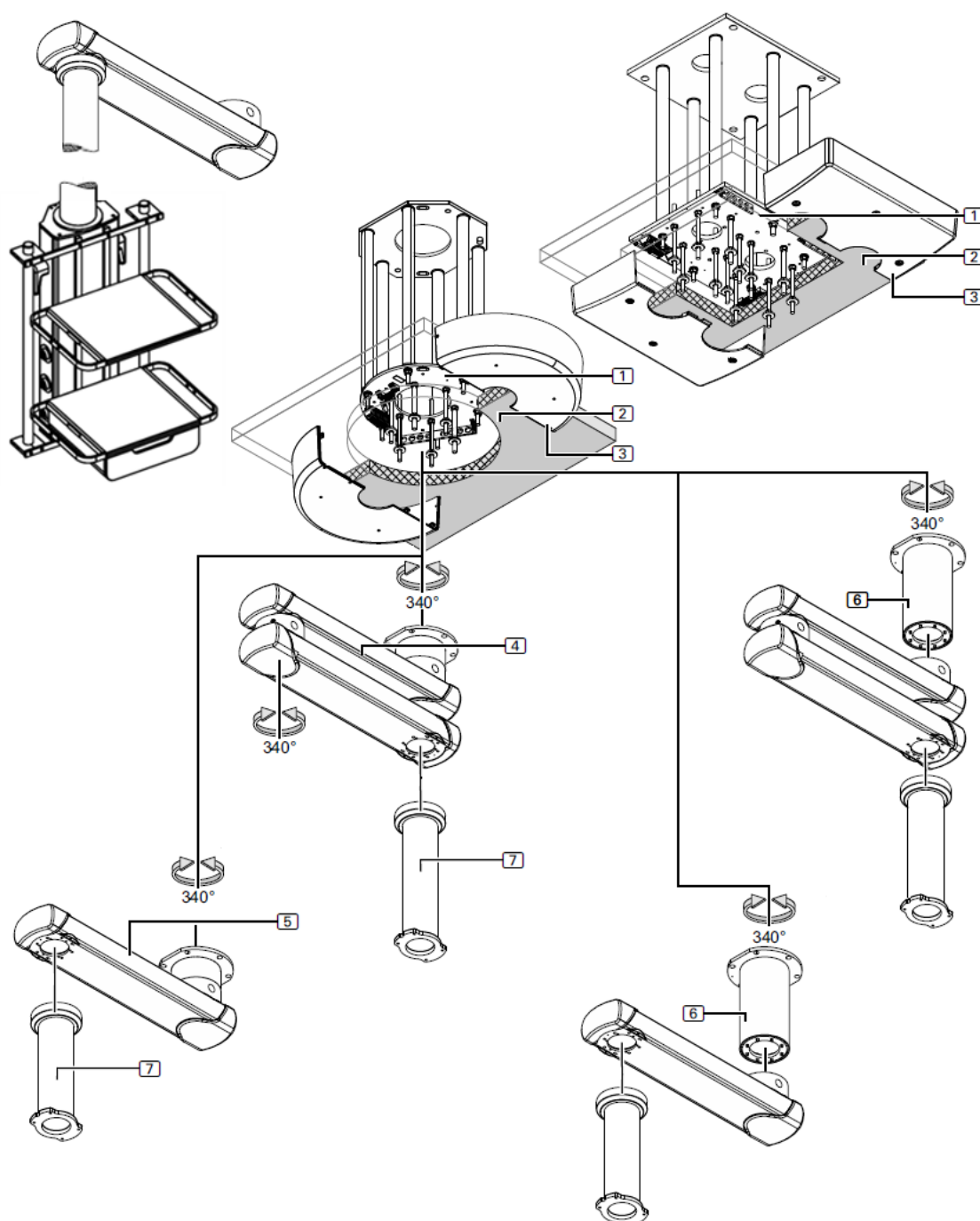





Fig. 3 COLUMN AIR, COLUMN AIRPLUS, COLUMN FRICTION

1	Interface plate (Single / Double) - pre-assembled
2	False Ceiling (own installation)
3	Roof trim (depending on version)
 See section 6.9.1 of this manual.	
Material included: - 4 / 6 metal screws, 4 / 6 cover screws and 1 sectional strip - 4/6 threaded bolts M10 x 360mm, 4/6 hex nuts M10	

4	Extension arm with pre-assembled roof tube - double arm variant.
	<p>See section 6.6.5 of this manual.</p> <p>Material included:</p> <ul style="list-style-type: none"> <li>- 2 friction-brake extension arms with roof tube</li> <li>- 3 earthing wires, 4mm<sup>2</sup> 3 grounding wires, 4mm<sup>2</sup> 3 grounding wires, 4mm<sup>2</sup> 3 grounding wires, 4mm</li> <li>- 2 set screws M16 - DIN EN ISO 4028</li> <li>- 4 ball stops Ø10mm - DIN 5401, ISO 3290</li> <li>- 4 End caps for extension arm</li> <li>- 12 hex nuts M16 and 6 elastic rings</li> <li>- 12 flat washers 34 mm outside diameter and 12 insulating discs</li> <li>- 6 threaded bolts M16 x 330mm</li> </ul>
5	Extension arm with pre-assembled roof tube - single arm variant
	<p>See section 6.6.5 of this manual.</p> <p>Material included:</p> <ul style="list-style-type: none"> <li>- 1 friction brake extension arm with roof tube</li> <li>- 2 earthing cable, 4mm<sup>2</sup> 2 grounding cable, 4mm<sup>2</sup> 2 grounding cable, 4mm<sup>2</sup> 2 grounding cable, 4mm</li> <li>- 1 set screw M16 - DIN EN ISO 4028</li> <li>- 2 ball stoppers Ø10mm - DIN 5401, ISO 3290</li> <li>- 2 End caps for extension arm</li> <li>- 12 hexagon nuts M16 and 6 elastic rings</li> <li>- 12 flat washers of 34 mm outer diameter and 12 insulating discs</li> <li>- 6 threaded bolts M16 x 330mm</li> </ul>
6	Ceiling tube (for long ceiling tube lengths)
	<p>See section 6.6.2 of this manual.</p> <p>Material included:</p> <ul style="list-style-type: none"> <li>- 1 roof tube (length specified in the order)</li> <li>- 1 grounding cable, 4mm<sup>2</sup> 1 grounding cable, 4mm<sup>2</sup> 1 grounding cable, 4mm<sup>2</sup> 1 grounding cable, 4mm</li> <li>- 1 long pipe spanner (for ceiling pipe lengths of 500 and 700 mm)</li> <li>- 8 socket head cap screws M10 x 25 mm - 8.8 - DIN EN ISO 4762</li> <li>- 8 lock washers S10</li> </ul>

<b>7</b>	<b>Drop tube with friction bearing unit (slide bearing/roller bearing)</b>
----------	--



See section 6.6.7 of this manual.

Material included:

- 1 drop tube (length specified in order)
- 1 grounding cable, 4mm<sup>2</sup> 1 grounding cable, 4mm<sup>2</sup> 1 grounding cable, 4mm<sup>2</sup> 1 grounding cable, 4mm
- 1 mounting plate 8 x M10
- 8 countersunk socket head cap screws M10 x 25 mm - 8.8 - DIN EN ISO 10642

(Included in the packaging of the service head)

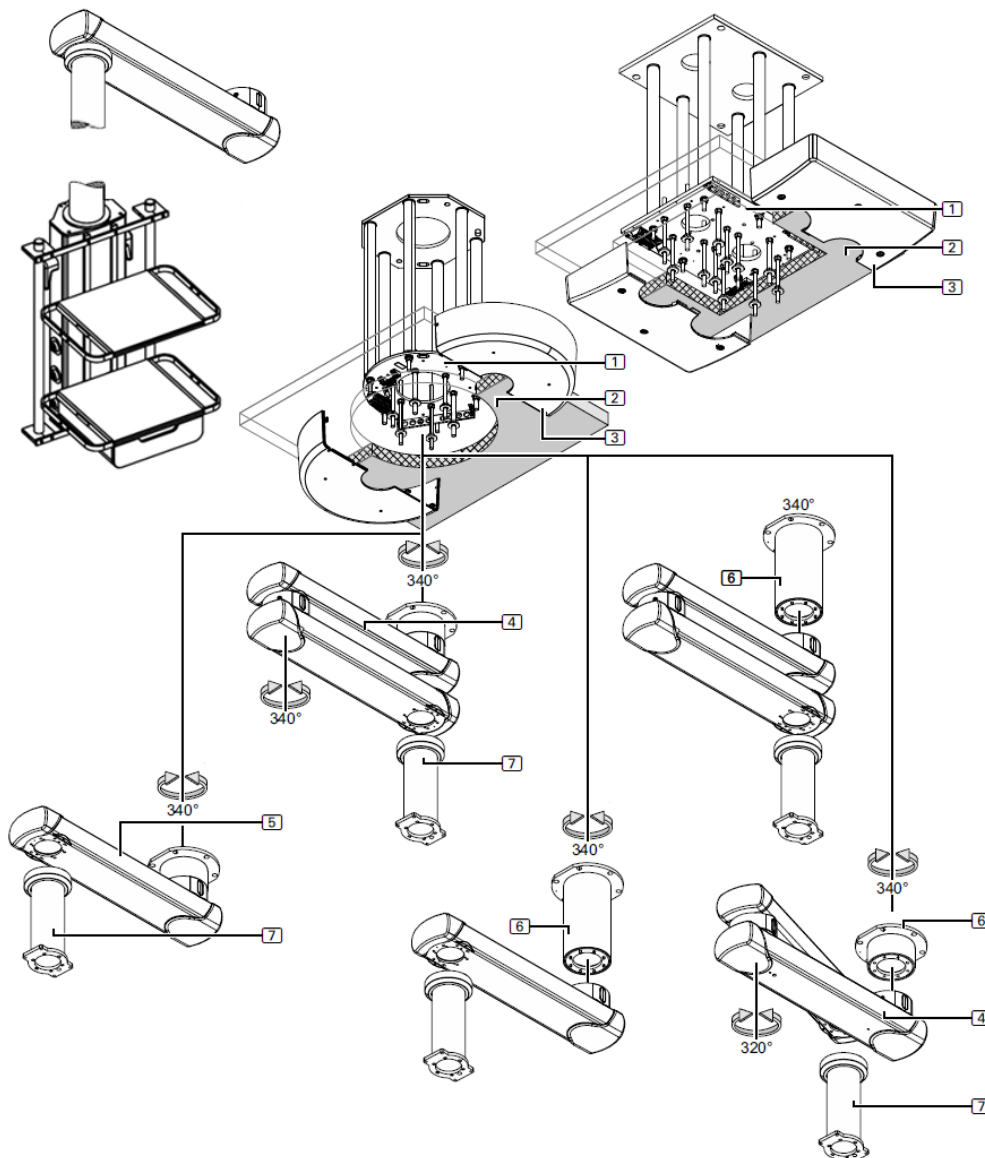







Fig. 4 COLUMN, INVERTED COLUMN, COLUMN XL, COLUMN XXL

1	Interface plate (Single / Double) - pre-assembled
2	False Ceiling (own installation)
3	Roof trim (depending on version)
	 See section 6.9.1 of this manual. Material included: <ul style="list-style-type: none"> <li>- 4 / 6 metal screws, 4 / 6 cover screws and 1 sectional strip</li> <li>- 4/6 threaded bolts M10 x 360mm, 4/6 hex nuts M10</li> </ul>
4	Extension arm with pre-assembled roof tube - double arm variant.
	 See section 6.6.5 of this manual. Material included: <ul style="list-style-type: none"> <li>- 2 pre-mounted brake extension arms (depending on model/s chosen)</li> <li>- 1 power cable</li> <li>- 1 power supply cable for the electromagnetic brake</li> <li>- 1 signal cable for electromagnetic brake (in protective tube)</li> <li>- 3 earthing wires, 4mm<sup>2</sup> 3 grounding wires, 4mm<sup>2</sup> 3 grounding wires, 4mm<sup>2</sup> 3 grounding wires, 4mm</li> </ul>
	- 2 x Screw DIN EN ISO 4028 M16+ 4x ball stop DIN5401, ISO 3290 Ø12,7mm <b>(For COLUMN and INVERTED COLUMN)</b>
	- 1 x Screw DIN EN ISO 4028 M16+ 2x ball stop DIN5401, ISO 3290 Ø12,7mm - 1 x Screw DIN EN ISO 4028 M20+ 2x ball stop DIN5401, ISO 3290 Ø16mm <b>(For COLUMN XL)</b>
	- 2 x Screw DIN EN ISO 4028 M20+ 4x ball stop DIN5401, ISO 3290 Ø16mm <b>(For COLUMN XXL)</b>
	<ul style="list-style-type: none"> <li>- 4 End caps for extension arm</li> <li>- 12 hex nuts M16 and 6 elastic rings</li> <li>- 12 flat washers 34 mm outside diameter and 12 insulating discs</li> <li>- 6 threaded bolts M16 x 330mm</li> </ul>
5	Extension arm with pre-assembled roof tube - single arm variant
	 See section 6.6.5 of this manual. Material included: <ul style="list-style-type: none"> <li>- 1 extension arm with roof tube</li> <li>- 1 power cable</li> <li>- 1 power supply cable for electromagnetic brake</li> <li>- 1 signal cable for electromagnetic brake (in protective tube)</li> <li>- 2 earthing cable, 4mm<sup>2</sup> 2 grounding cable, 4mm<sup>2</sup> 2 grounding cable, 4mm<sup>2</sup> 2 grounding cable, 4mm</li> </ul>
	- 2 x Screw DIN EN ISO 4028 M16+ 4x ball stop DIN5401, ISO 3290 Ø12,7mm <b>(For COLUMN and INVERTED COLUMN)</b>

	<ul style="list-style-type: none"> <li>- 1 x Screw DIN EN ISO 4028 M20+ 2x ball stop DIN5401, ISO 3290 Ø16mm</li> </ul> <p><b>(For COLUMN XL)</b></p>
	<ul style="list-style-type: none"> <li>- 2 End caps for extension arm</li> <li>- 12 hexagon nuts M16 and 6 elastic rings</li> <li>- 12 flat washers 34 mm outside diameter and 12 insulating discs</li> <li>- 6 threaded bolts M16 x 330mm</li> </ul>
6	 <p>Ceiling tube (for long ceiling tube lengths)</p>
	 <p>See section 6.6.2 of this manual.</p> <p>Material included:</p> <ul style="list-style-type: none"> <li>- 1 ceiling pipe (length specified in the order)</li> <li>- 1 grounding cable, 4mm<sup>2</sup> 1 grounding cable, 4mm<sup>2</sup> 1 grounding cable, 4mm<sup>2</sup> 1 grounding cable, 4mm</li> <li>- 1 long pipe spanner (for ceiling pipe lengths of 500 and 700 mm)</li> </ul>
	<ul style="list-style-type: none"> <li>- 8 socket head cap screws M10 x 25 mm - 8.8 - DIN EN ISO 4762</li> </ul> <p><b>(For COLUMN and INVERTED COLUMN)</b></p>
	<ul style="list-style-type: none"> <li>- 10 hexagon socket head cap screws M10 x 30 mm - 8.8 - DIN EN ISO 4762</li> </ul> <p><b>(for COLUMN XL and COLUMN XXL)</b></p>
	<ul style="list-style-type: none"> <li>- 8 lock washers S10</li> </ul> <p><b>(For COLUMN and INVERTED COLUMN)</b></p>
	<ul style="list-style-type: none"> <li>- 10 lock washers S10</li> </ul> <p><b>(for COLUMN XL and COLUMN XXL)</b></p>
7	<p>Drop tube with friction bearing unit (plain bearing/roller bearing)</p>
	 <p>See section 6.6.7 of this manual.</p> <p>Material included:</p> <ul style="list-style-type: none"> <li>- 1 drop tube (length specified in order)</li> <li>- 1 grounding cable, 4mm<sup>2</sup> 1 grounding cable, 4mm<sup>2</sup> 1 grounding cable, 4mm<sup>2</sup> 1 grounding cable, 4mm</li> <li>- 1 mounting plate 8 x M10</li> </ul>
	<ul style="list-style-type: none"> <li>- 8 countersunk socket head cap screws M10 x 25 mm - 8.8 - DIN EN ISO 10642</li> </ul> <p>(Included in the packaging of the service head)</p> <p><b>(For COLUMN and INVERTED COLUMN)</b></p>

- 8 countersunk socket head cap screws M10 x 30 mm - 8.8 - DIN EN ISO 10642  
(Included in the packaging of the service head)  
**(For COLUMN XL and COLUMN XXL)**

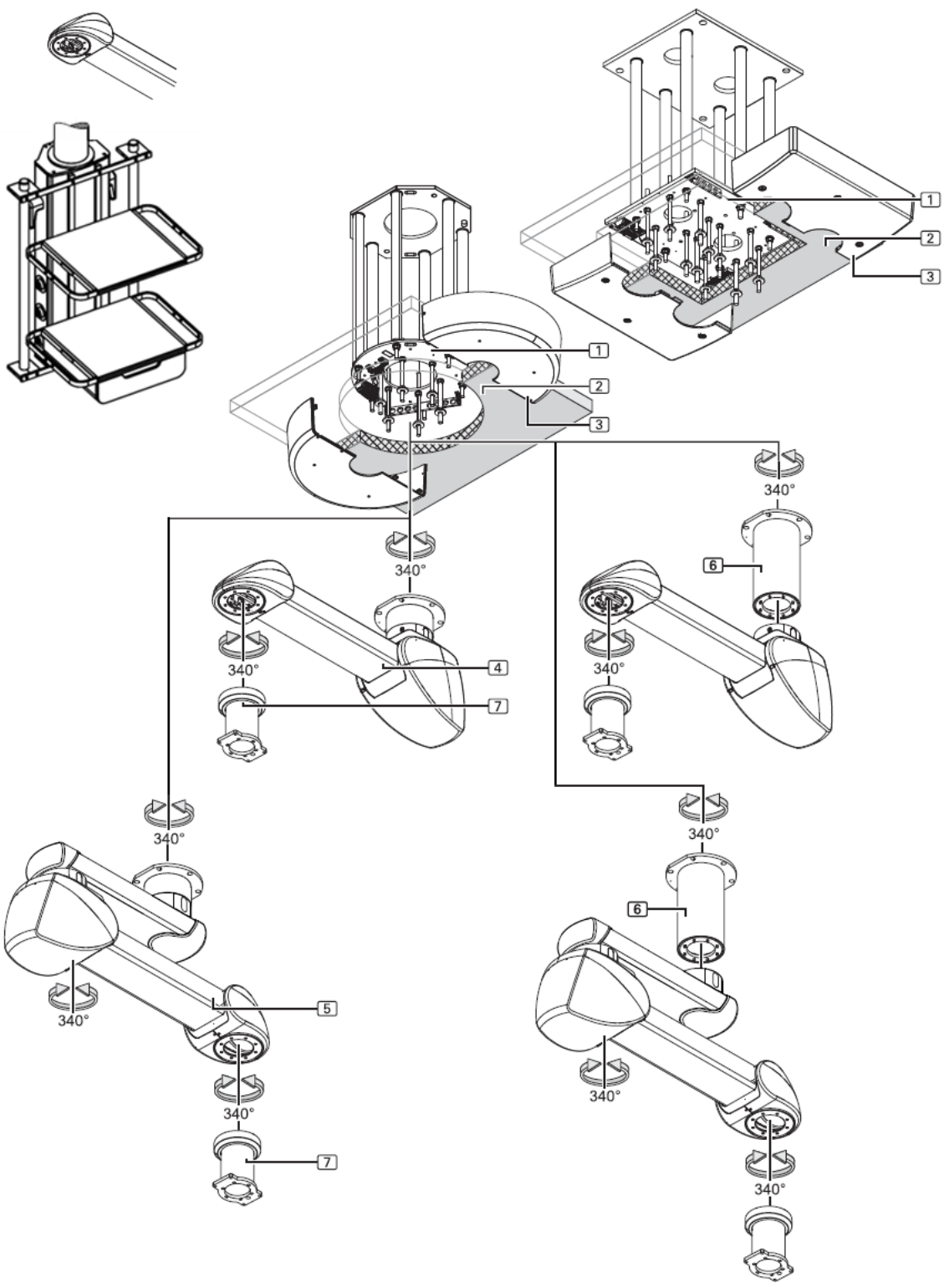







Fig. 5 COLUMN MOTOR, COLUMN MOTOR XL, COLUMN MOTOR XXL

1	Interface board (Single / Double) - pre-assembled
2	False Ceiling (own installation)
3	Roof trim (depending on version)
	 See section 6.9.1 of this manual. Material included: <ul style="list-style-type: none"> <li>- 4 / 6 metal screws, 4 / 6 cover screws and 1 sectional strip</li> <li>- 4/6 threaded bolts M10 x 360mm, 4/6 hex nuts M10</li> </ul>
4	Motorised arm with pre-mounted ceiling tube - single arm variant
	 See section 6.6.5 of this manual. Material included: <ul style="list-style-type: none"> <li>- 1 motor arm</li> <li>- 1 power cable</li> <li>- 1 power supply cable for electromagnetic brake</li> <li>- 1 signal cable for electromagnetic brake (in protective tube)</li> <li>- 3 earthing wires, 4mm<sup>2</sup> 3 grounding wires, 4mm<sup>2</sup> 3 grounding wires, 4mm<sup>2</sup> 3 grounding wires, 4mm</li> <li>- 1 x screw DIN EN ISO 4028 M16+ 2x ball stopper DIN5401, ISO 3290 Ø12,7mm</li> <li>- 2 voltage selection sockets for power supply 120V / 230V</li> <li>- 2 End caps for extension arm</li> <li>- 4 side panels, front right/left connection for motor arm</li> <li>- 1 cover, rear hinge, for motor arm</li> <li>- 1 cover, front hinge, for motor arm</li> <li>- 2 cover straps, rear hinged, for motor arm</li> <li>- 2 cover straps, front hinged, for motor arm</li> <li>- 12 hex nuts M16 and 6 elastic rings</li> <li>- 12 flat washers 34 mm outside diameter and 12 insulating discs</li> <li>- 6 threaded bolts M16 x 330mm</li> </ul>
5	Motorised arm with pre-assembled ceiling tube - double arm variant
	 See section 6.6.5 of this manual. Material included: <ul style="list-style-type: none"> <li>- 1 extension arm with an attached motor arm</li> <li>- 1 power cable</li> <li>- 1 power supply cable for the electromagnetic brake</li> <li>- 1 signal cable for electromagnetic brake (in protective tube)</li> <li>- 4 earthing cables, 4mm<sup>2</sup> (3 for unassembled roof tube)</li> <li>- 2 x Screw DIN EN ISO 4028 M16+ 4x ball stop DIN5401, ISO 3290 Ø12,7mm</li> </ul>



<b>(For COLUMN MOTOR)</b>	
<ul style="list-style-type: none"> <li>- 1 x Screw DIN EN ISO 4028 M16+ 2x ball stop DIN5401, ISO 3290 Ø12,7mm</li> <li>- 1 x screw DIN EN ISO 4028 M20+ 2x ball stopper DIN5401, ISO 3290 Ø16mm</li> </ul>	
<b>(For COLUMN MOTOR XL)</b>	
<ul style="list-style-type: none"> <li>- 2 voltage selection sockets for power supply 120V / 230V</li> <li>- 4 side panels, front right/left connection for motor arm</li> <li>- 1 cover, rear hinge, for motor arm</li> <li>- 1 cover, front hinge, for motor arm</li> <li>- 2 cover straps, rear hinged, for motor arm</li> <li>- 2 cover straps, front hinged, for motor arm</li> <li>- 12 hexagon nuts M16 and 6 elastic rings</li> <li>- 12 flat washers 34 mm outside diameter and 12 insulating discs</li> <li>- 6 threaded bolts M16 x 330mm</li> </ul>	
<b>6</b>	Ceiling tube
	See section 6.6.2 of this manual.
Material included:	<ul style="list-style-type: none"> <li>- 1 roof tube (length specified in the order)</li> <li>- 1 grounding cable, 4mm<sup>2</sup> 1 grounding cable, 4mm<sup>2</sup> 1 grounding cable, 4mm<sup>2</sup> 1 grounding cable, 4mm</li> <li>- 1 long pipe spanner (for 500 and 700 mm ceiling pipe lengths)</li> </ul>
<ul style="list-style-type: none"> <li>- 8 socket head cap screws M10 x 25 mm - 8.8 - DIN EN ISO 4762</li> </ul>	
<b>(For COLUMN MOTOR)</b>	
<ul style="list-style-type: none"> <li>- 10 hexagon socket head cap screws M10 x 30 mm - 8.8 - DIN EN ISO 4762</li> </ul>	
<b>(For COLUMN MOTOR XL)</b>	
<ul style="list-style-type: none"> <li>- 8 lock washers S10</li> </ul>	
<b>(For COLUMN MOTOR)</b>	
<ul style="list-style-type: none"> <li>- 10 lock washers S10</li> </ul>	
<b>(For COLUMN MOTOR XL)</b>	
<b>7</b>	Drop tube
	See section 6.6.7 of this manual.
Material included:	<ul style="list-style-type: none"> <li>- 1 drop tube (length specified when ordering)</li> </ul>

- 1 grounding cable, 4mm<sup>2</sup> 1 grounding cable, 4mm<sup>2</sup> 1 grounding cable, 4mm<sup>2</sup> 1 grounding cable, 4mm
- 1 mounting plate 8 x M10
- 8 countersunk socket head cap screws M10 x 18 mm - 10.9 - DIN EN ISO 10642  
(Included in the packaging of the service head)

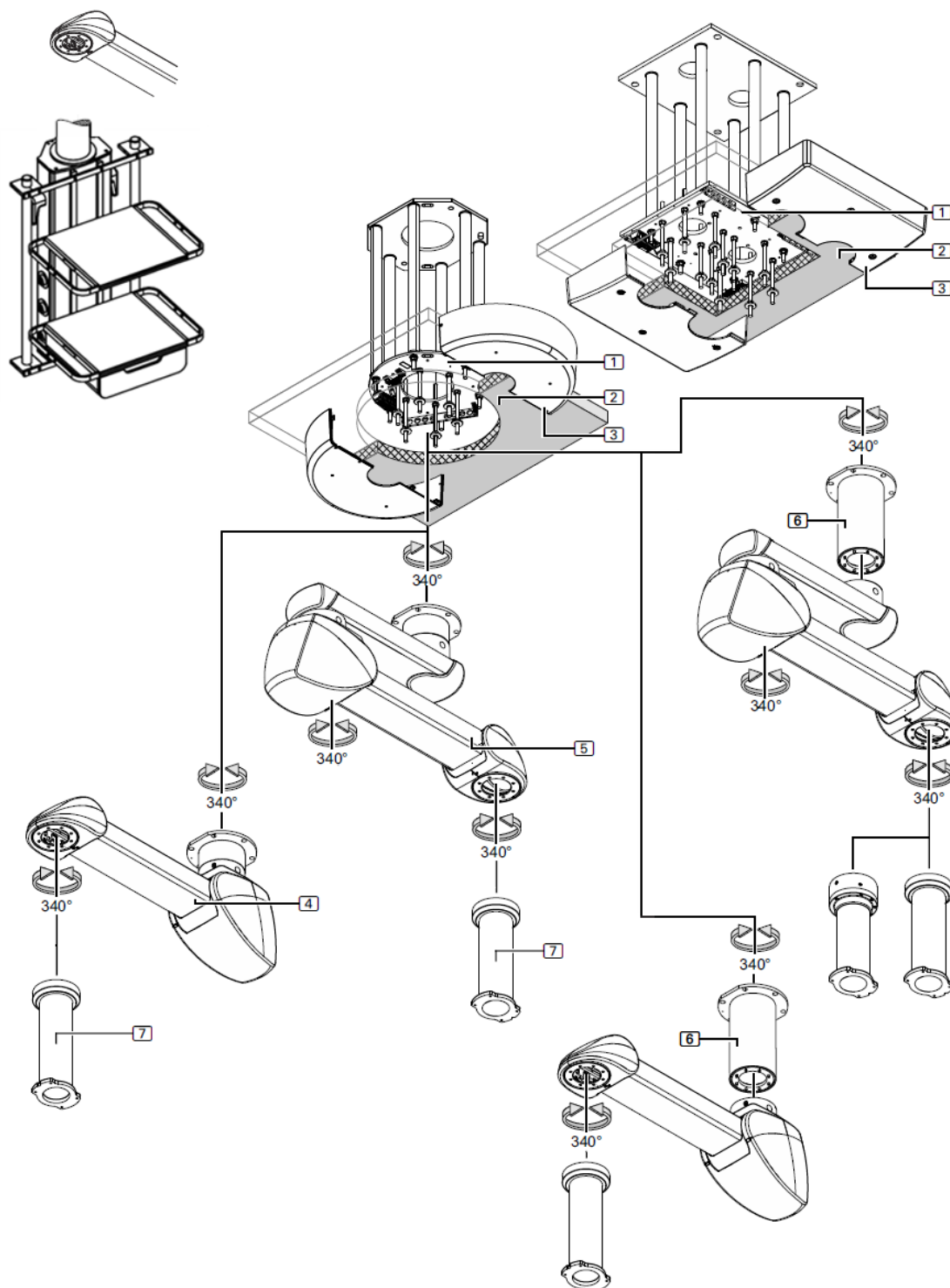







Fig. 6 COLUMN MOTOR AIRPLUS, COLUMN MOTOR FRICTION

1	Interface plate (Single / Double) - pre-assembled
2	False Ceiling (own installation)
3	Roof trim (depending on version)
	See section 6.9.1 of this manual.
Material included:	<ul style="list-style-type: none"> <li>- 4 / 6 metal screws, 4 / 6 cover screws and 1 sectional strip</li> <li>- 4/6 threaded bolts M10 x 360mm, 4/6 hex nuts M10</li> </ul>
4	Motorised arm with pre-mounted ceiling tube - single arm variant
	See section 6.6.5 of this manual.
Material included:	<ul style="list-style-type: none"> <li>- 1 motor arm</li> <li>- 1 power cable</li> <li>- 2 pneumatic tubes for brake control (only for AIRPLUS)</li> <li>- 3 earthing wires, 4mm<sup>2</sup> 3 grounding wires, 4mm<sup>2</sup> 3 grounding wires, 4mm<sup>2</sup> 3 grounding wires, 4mm</li> </ul>
	<ul style="list-style-type: none"> <li>- 1 x Screw DIN EN ISO 4028 M16+ 2x ball stop DIN5401, ISO 3290 Ø12,7mm</li> </ul> <p><b>(For COLUMN MOTOR AIRPLUS)</b></p>
	<ul style="list-style-type: none"> <li>- 1 x screw DIN EN ISO 4028 M16+ 2x ball stopper DIN5401, ISO 3290 Ø10mm</li> </ul> <p><b>(For COLUMN MOTOR FRICTION)</b></p>
	<ul style="list-style-type: none"> <li>- 2 voltage selection sockets for power supply 120V / 230V</li> <li>- 2 End caps for the extension arm</li> <li>- 4 side panels, front right/left connection for motor arm</li> <li>- 1 cover, rear hinge, for motor arm</li> <li>- 1 cover, front hinge, for motor arm</li> <li>- 2 cover straps, rear hinged, for motor arm</li> <li>- 2 cover straps, front hinged, for motor arm</li> <li>- 12 hexagon nuts M16 and 6 elastic rings</li> <li>- 12 flat washers of 34 mm outer diameter and 12 insulating discs</li> <li>- 6 threaded bolts M16 x 330mm</li> </ul>
5	Motorised arm with pre-assembled ceiling tube - double arm variant
	See section 6.6.5 of this manual.

Material included:		<ul style="list-style-type: none"> <li>- 1 extension arm with an attached motor arm</li> <li>- 1 power cable</li> <li>- 3 pneumatic tubes for brake control (only for AIRPLUS)</li> <li>- 4 earthing cables, 4mm<sup>2</sup> (3 for unassembled roof tube)</li> </ul>
		<ul style="list-style-type: none"> <li>- 2 x Screw DIN EN ISO 4028 M16+ 4x ball stop DIN5401, ISO 3290 Ø12,7mm</li> </ul> <p><b>(For COLUMN MOTOR AIRPLUS)</b></p>
		<ul style="list-style-type: none"> <li>- 2 x Screw DIN EN ISO 4028 M16+ 4x ball stop DIN5401, ISO 3290 Ø10mm</li> </ul> <p><b>(For COLUMN MOTOR FRICTION)</b></p>
		<ul style="list-style-type: none"> <li>- 2 voltage selection sockets for power supply 120V / 230V</li> <li>- 4 side panels, front right/left connection for motor arm</li> <li>- 1 cover, rear hinge, for motor arm</li> <li>- 1 cover, front hinge, for motor arm</li> <li>- 2 cover straps, rear hinged, for motor arm</li> <li>- 2 cover straps, front hinged, for motor arm</li> <li>- 12 hexagon nuts M16 and 6 elastic rings</li> <li>- 12 flat washers 34 mm outside diameter and 12 insulating discs</li> <li>- 6 threaded bolts M16 x 330mm</li> </ul>
<b>6</b>	Ceiling tube	
		 See section 6.6.2 of this manual.
Material included:		<ul style="list-style-type: none"> <li>- 1 roof tube (length specified in the order)</li> <li>- 1 grounding cable, 4mm<sup>2</sup> 1 grounding cable, 4mm<sup>2</sup> 1 grounding cable, 4mm<sup>2</sup> 1 grounding cable, 4mm</li> <li>- 1 long pipe spanner (for ceiling pipe lengths of 500 and 700 mm)</li> <li>- 8 socket head cap screws M10 x 25 mm - 8.8 - DIN EN ISO 4762</li> <li>- 8 lock washers S10</li> </ul>
<b>7</b>	Drop tube	
		 See section 6.6.7 of this manual.
Material included:		<ul style="list-style-type: none"> <li>- 1 drop tube (length specified when ordering)</li> <li>- 1 grounding cable, 4mm<sup>2</sup> 1 grounding cable, 4mm<sup>2</sup> 1 grounding cable, 4mm<sup>2</sup> 1 grounding cable, 4mm</li> <li>- 1 mounting plate 8 x M10</li> <li>- 8 countersunk socket head cap screws M10 x 18 mm - 10.9 - DIN EN ISO 10642</li> </ul> <p>(Included in the packaging of the service head)</p>

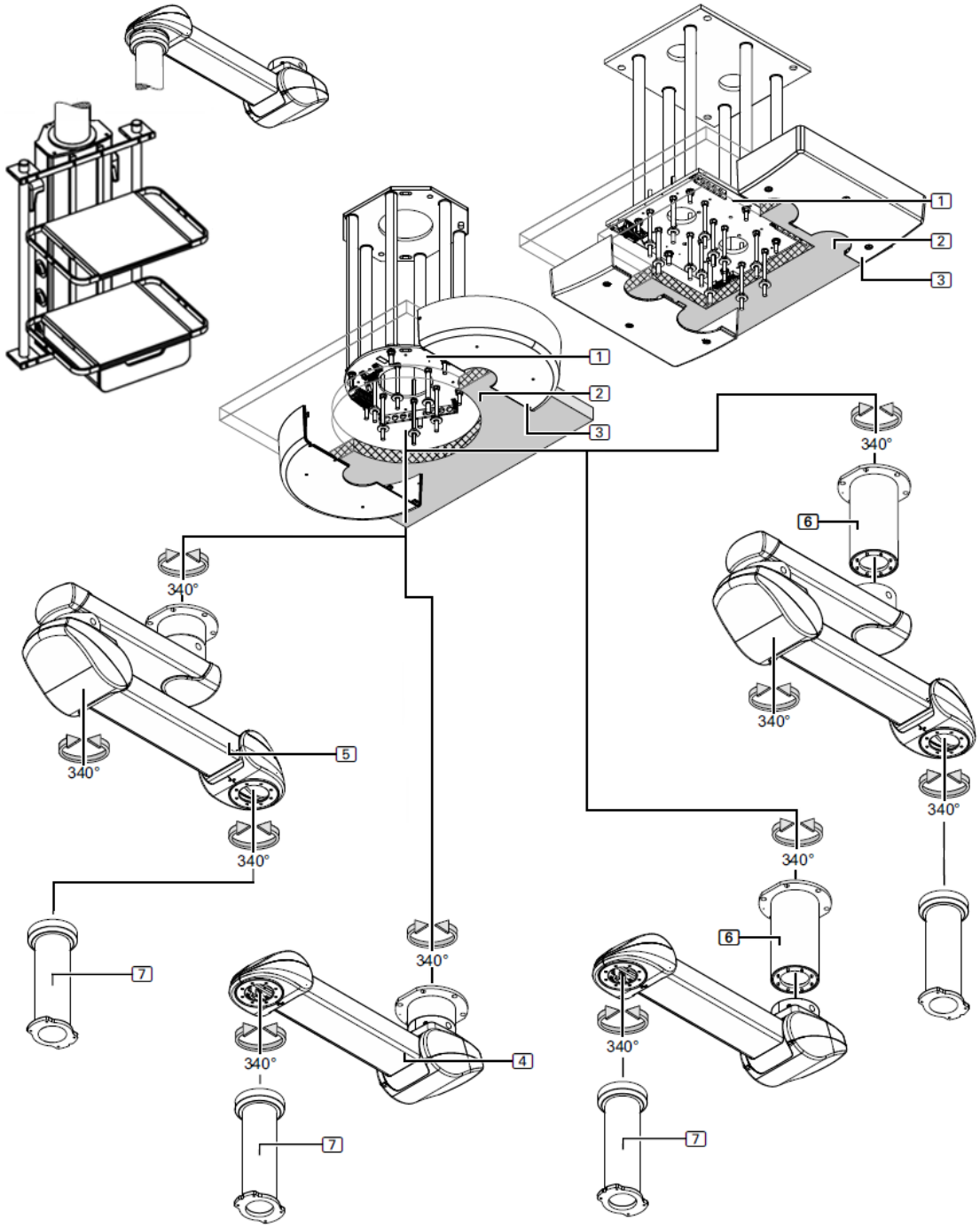







Fig. 7 COLUMN SPRING AIRPLUS, COLUMN SPRING FRICTION

1	Interface plate (Single / Double) - pre-assembled
2	False Ceiling (own installation)
3	Roof trim (depending on version)
	See section 6.9.1 of this manual.
Material included:	<ul style="list-style-type: none"> <li>- 4 / 6 metal screws, 4 / 6 cover screws and 1 sectional strip</li> <li>- 4/6 threaded bolts M10 x 360mm, 4/6 hex nuts M10</li> </ul>
4	Spring arm with pre-assembled ceiling tube - single arm variant
	See section 6.6.5 of this manual.
Material included:	<ul style="list-style-type: none"> <li>- 1 spring-loaded arm</li> <li>- 1 power cable</li> <li>- 3 pneumatic tubes for brake control (AIRPLUS only)</li> <li>- 2 grounding wires, 4mm<sup>2</sup> 2 grounding wires, 4mm<sup>2</sup> 2 grounding wires, 4mm<sup>2</sup> 2 grounding wires, 4mm</li> </ul>
	<ul style="list-style-type: none"> <li>- 1 x Screw DIN EN ISO 4028 M16+ 2x ball stop DIN5401, ISO 3290 Ø12,7mm</li> </ul> <p><b>(For COLUMN SPRING AIRPLUS)</b></p>
	<ul style="list-style-type: none"> <li>- 1 x screw DIN EN ISO 4028 M16+ 2x ball stopper DIN5401, ISO 3290 Ø10mm</li> </ul> <p><b>(For COLUMN SPRING FRICTION)</b></p>
	<ul style="list-style-type: none"> <li>- 2 End caps for extension arm</li> <li>- 4 side panels, front right/left connection for motor arm</li> <li>- 1 cover, rear hinge, for motor arm</li> <li>- 1 cover, front hinge, for motor arm</li> <li>- 2 cover straps, rear hinged, for motor arm</li> <li>- 2 cover straps, front hinge, for motor arm</li> <li>- 12 hexagon nuts M16 and 6 elastic rings</li> <li>- 12 flat washers of 34 mm outer diameter and 12 insulating discs</li> <li>- 6 threaded bolts M16 x 330mm</li> </ul>
5	Motorised arm with pre-assembled ceiling tube - double arm variant
	See section 6.6.5 of this manual.
Material included:	<ul style="list-style-type: none"> <li>- 1 extension arm with one spring-loaded arm attached</li> <li>- 1 power cable</li> <li>- 3 pneumatic tubes for brake control (AIRPLUS only)</li> <li>- 3 earthing cables, 4mm<sup>2</sup> (2 for unassembled roof tube)</li> </ul>
	<ul style="list-style-type: none"> <li>- 2 x Screw DIN EN ISO 4028 M16+ 4x ball stop DIN5401, ISO 3290 Ø12,7mm</li> </ul> <p><b>(For COLUMN SPRING AIRPLUS)</b></p>

		- 2 x Screw DIN EN ISO 4028 M16+ 4x ball stop DIN5401, ISO 3290 Ø10mm
		<b>(For COLUMN SPRING FRICTION)</b>
		- 4 side panels, front right/left connection for motor arm - 1 cover, rear hinge, for motor arm
		- 1 cover, front hinge, for motor arm - 2 cover straps, rear hinged, for motor arm - 2 cover straps, front hinge, for motor arm - 12 hex nuts M16 and 6 elastic rings - 12 flat washers 34 mm outside diameter and 12 insulating discs - 6 threaded bolts M16 x 330mm
<b>6</b>	Ceiling tube	
		See section 6.6.2 of this manual.
	Material included:	- 1 ceiling pipe (length specified in the order) - 1 grounding cable, 4mm <sup>2</sup> 1 grounding cable, 4mm <sup>2</sup> 1 grounding cable, 4mm <sup>2</sup> 1 grounding cable, 4mm - 1 long pipe spanner (for ceiling pipe lengths of 500 and 700 mm) - 8 socket head cap screws M10 x 25 mm - 8.8 - DIN EN ISO 4762 - 8 lock washers S10
<b>7</b>	Drop tube	
		See section 6.6.7 of this manual.
	Material included:	- 1 drop tube (length specified in order) - 1 grounding cable, 4mm <sup>2</sup> 1 grounding cable, 4mm <sup>2</sup> 1 grounding cable, 4mm <sup>2</sup> 1 grounding cable, 4mm - 1 mounting plate 8 x M10 - 8 countersunk socket head cap screws M10 x 20 mm - 10.9 - DIN EN ISO 10642 (Included in the packaging of the service head)



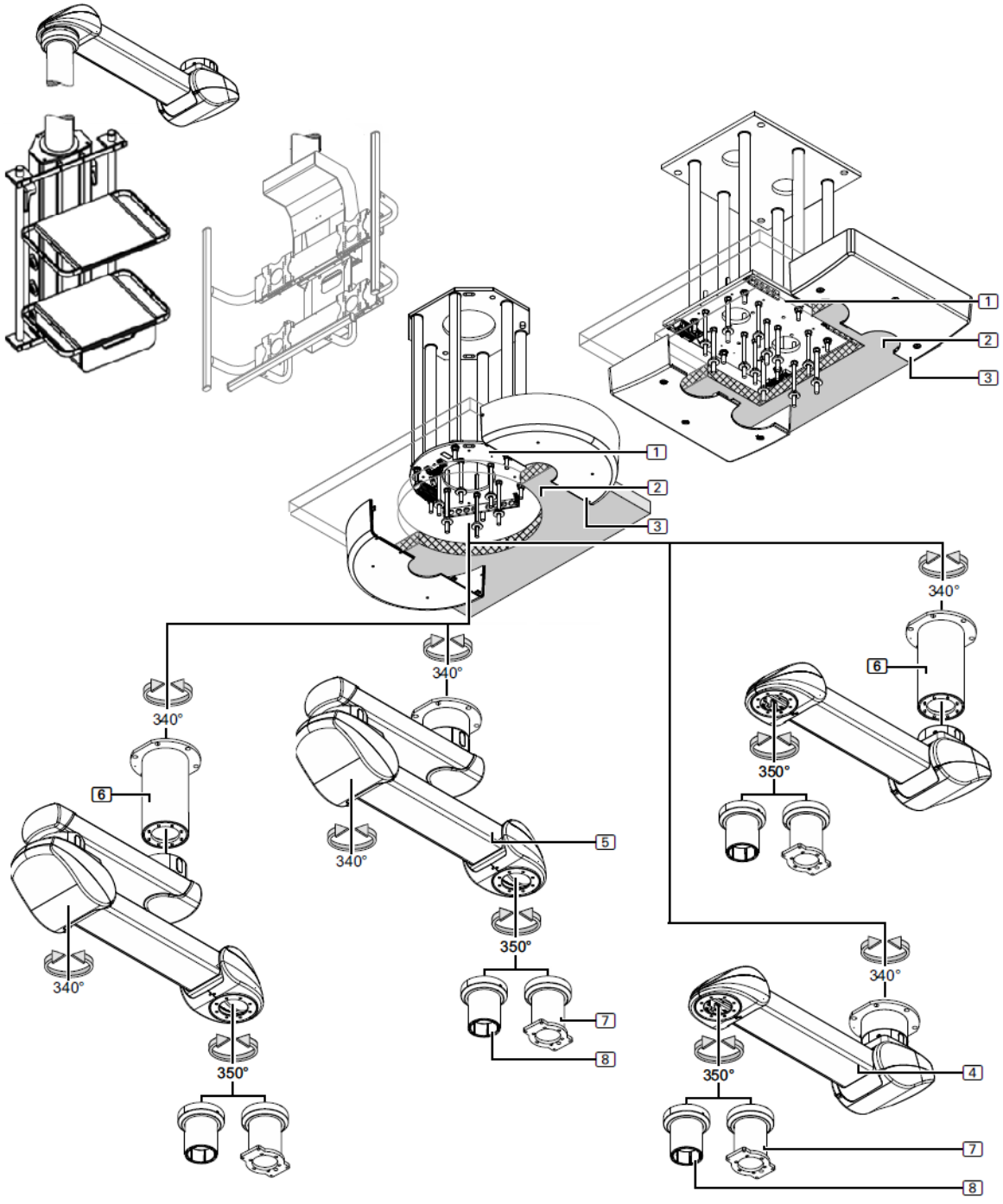







Fig. 8 COLUMN SPRING, COLUMN SPRING XL

1	Interface board (Single / Double) - pre-assembled
2	False Ceiling (own installation)
3	Roof trim (depending on version)
	 See section 6.9.1 of this manual. Material included: <ul style="list-style-type: none"> <li>- 4 / 6 metal screws, 4 / 6 cover screws and 1 sectional strip</li> <li>- 4/6 threaded bolts M10 x 360mm, 4/6 hex nuts M10</li> </ul>
4	Motorised arm with pre-assembled ceiling tube - single arm variant
	 See section 6.6.5 of this manual. Material included: <ul style="list-style-type: none"> <li>- 1 spring-loaded arm</li> <li>- 1 power cable</li> <li>- 1 power supply cable for the electromagnetic brake</li> <li>- 1 signal cable for electromagnetic brake (in protective tube)</li> <li>- 2 grounding wires, 4mm<sup>2</sup> 2 grounding wires, 4mm<sup>2</sup> 2 grounding wires, 4mm<sup>2</sup> 2 grounding wires, 4mm</li> <li>- 1 x Screw DIN EN ISO 4028 M16+ 2x ball stop DIN5401, ISO 3290 Ø12,7mm</li> <li>- 2 End caps for the extension arm</li> <li>- 4 side panels, right/left front connection for spring-loaded arm</li> <li>- 1 flap, rear hinge, for spring-loaded arm</li> <li>- 1 flap, front hinge, for spring-loaded arm</li> <li>- 2 cover straps, rear hinged, for spring-loaded arm</li> <li>- 2 cover straps, front hinge, for spring-loaded arm</li> <li>- 12 hex nuts M16 and 6 elastic rings</li> <li>- 12 flat washers 34 mm outside diameter and 12 insulating discs</li> <li>- 6 threaded bolts M16 x 330mm</li> </ul>
5	Spring arm with pre-mounted ceiling tube - double arm variant
	 See section 6.6.5 of this manual. Material included: <ul style="list-style-type: none"> <li>- 1 extension arm with one spring-loaded arm attached</li> <li>- 1 power cable</li> <li>- 1 power supply cable for the electromagnetic brake</li> <li>- 1 signal cable for electromagnetic brake (in protective tube)</li> <li>- 3 earthing cables, 4mm<sup>2</sup> (2 for unassembled roof tube)</li> </ul>
	<ul style="list-style-type: none"> <li>- 2 x Screw DIN EN ISO 4028 M16+ 4x ball stop DIN5401, ISO 3290 Ø12,7mm</li> </ul> <p><b>(For COLUMN SPRING)</b></p>

	<ul style="list-style-type: none"> <li>- 1 x Screw DIN EN ISO 4028 M16+ 2x ball stop DIN5401, ISO 3290 Ø12,7mm</li> <li>- 1 x Screw DIN EN ISO 4028 M20+ 2x ball stop DIN5401, ISO 3290 Ø16mm</li> </ul> <p><b>(For COLUMN SPRING XL)</b></p>
	<ul style="list-style-type: none"> <li>- 4 side panels, front right/left connection for spring-loaded arm</li> <li>- 1 flap, rear hinge, for spring-loaded arm</li> <li>- 1 flap, front hinge, for spring-loaded arm</li> <li>- 2 End caps for extension arm</li> <li>- 2 cover straps, rear hinged, for spring-loaded arm</li> <li>- 2 cover straps, front hinge, for spring-loaded arm</li> <li>- 12 hex nuts M16 and 6 elastic rings</li> <li>- 12 flat washers 34 mm outside diameter and 12 insulating discs</li> <li>- 6 threaded bolts M16 x 330mm</li> </ul>
<b>6</b>	Ceiling tube
	 <p>See section 6.6.2 of this manual.</p> <p>Material included:</p> <ul style="list-style-type: none"> <li>- 1 ceiling pipe (length specified in the order)</li> <li>- 1 grounding cable, 4mm<sup>2</sup> 1 grounding cable, 4mm<sup>2</sup> 1 grounding cable, 4mm<sup>2</sup> 1 grounding cable, 4mm</li> <li>- 1 long pipe spanner (for 500 and 700 mm roof pipe lengths)</li> </ul>
	<ul style="list-style-type: none"> <li>- 8 socket head cap screws M10 x 25 mm - 8.8 - DIN EN ISO 4762</li> </ul> <p><b>(For COLUMN SPRING)</b></p>
	<ul style="list-style-type: none"> <li>- 10 hexagon socket head cap screws M10 x 30 mm - 8.8 - DIN EN ISO 4762</li> </ul> <p><b>(For COLUMN SPRING XL)</b></p>
	<ul style="list-style-type: none"> <li>- 8 lock washers S10</li> </ul> <p><b>(For COLUMN SPRING)</b></p>
	<ul style="list-style-type: none"> <li>- 10 lock washers S10</li> </ul> <p><b>(For COLUMN SPRING XL)</b></p>
<b>7</b>	Drop tube with service head
	 <p>See section 6.6.7 of this manual.</p> <p>Material included:</p> <ul style="list-style-type: none"> <li>- 1 drop tube (length specified when ordering)</li> <li>- 1 grounding cable, 4mm<sup>2</sup> 1 grounding cable, 4mm<sup>2</sup> 1 grounding cable, 4mm<sup>2</sup> 1 grounding cable, 4mm</li> <li>- 1 mounting plate 8 x M10</li> <li>- 8 countersunk socket head cap screws M10 x 20 mm - 10.9 - DIN EN ISO 10642</li> </ul> <p>(Included in the packaging of the service head)</p>

<b>8</b>	Drop tube with monitor bracket
----------	--------------------------------



See section 6.6.7 of this manual.

Material included:

- 1 drop tube (length specified when ordering)
- 1 grounding cable, 4mm<sup>2</sup> 1 grounding cable, 4mm<sup>2</sup> 1 grounding cable, 4mm<sup>2</sup> 1 grounding cable, 4mm
- 8 countersunk socket head cap screws M10 x 20 mm - 10.9 - DIN EN ISO 10642  
(Included in the packaging of the monitor bracket)
- 6 socket head cap screws M8 x 35 mm - 8.8 - DIN EN ISO 4762
- 6 lock washers S8

## 6.2. Installation references. Accessories. Lighting, indicators.

When the system is delivered ex works, the following optional accessories are already fitted:

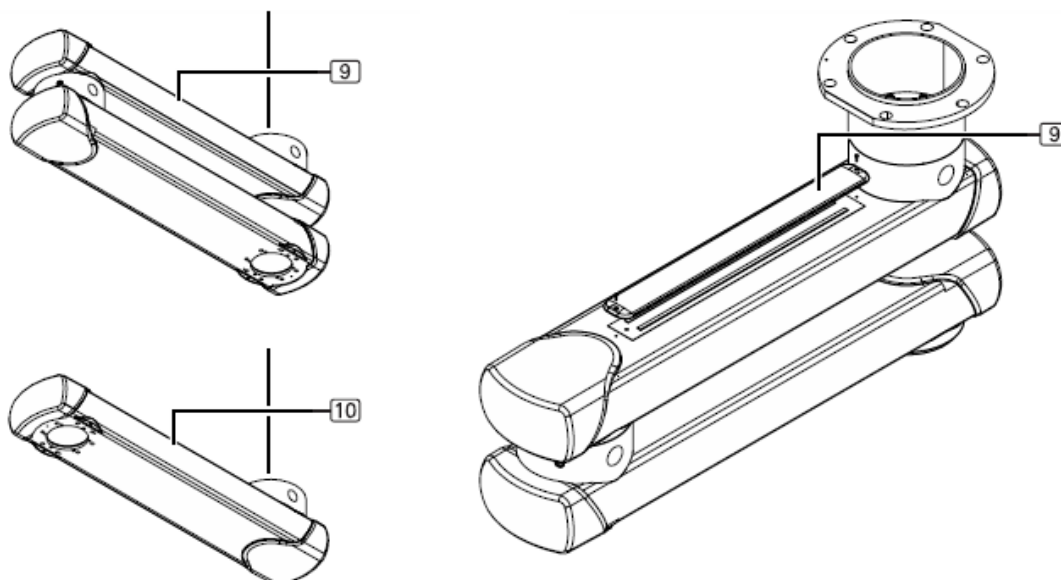

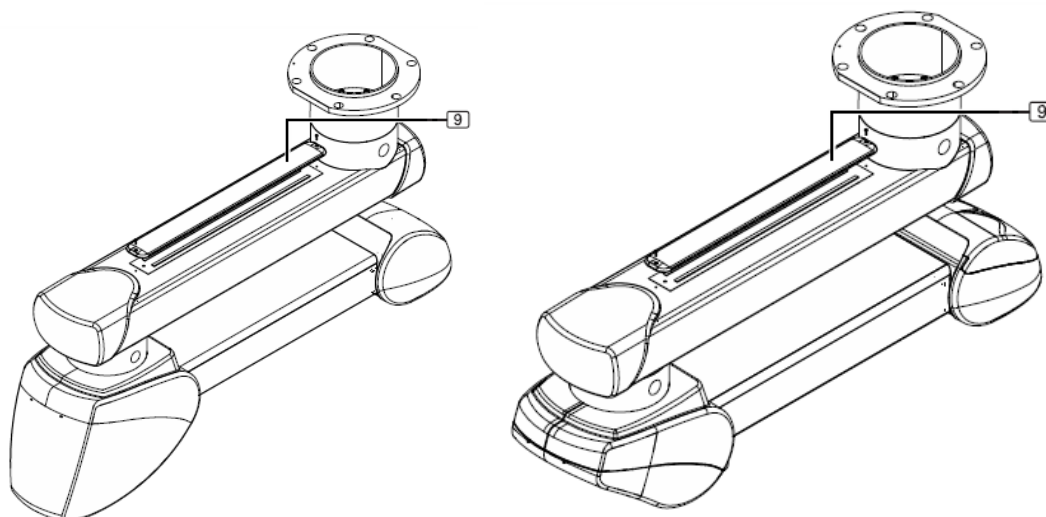

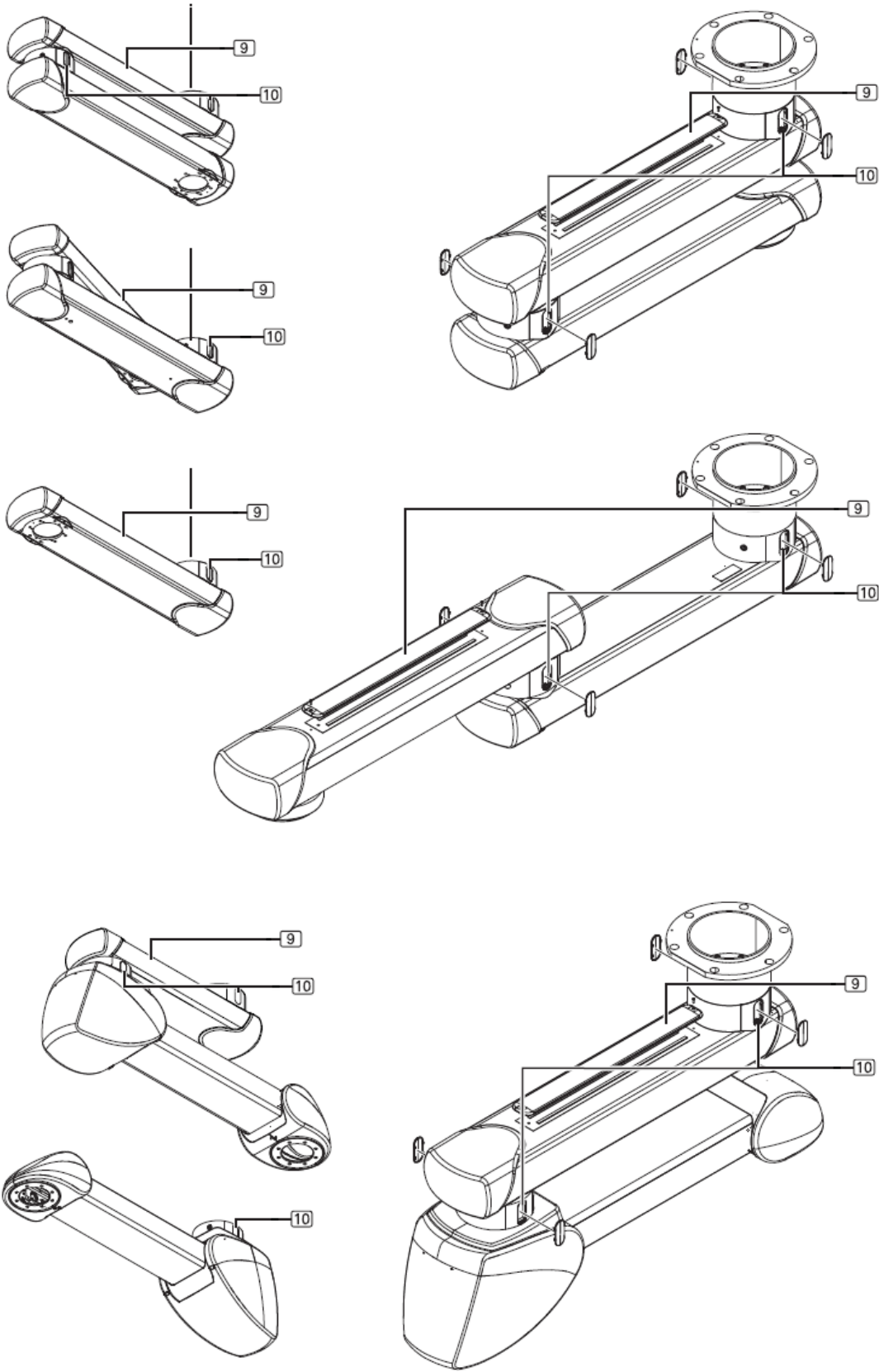

Fig. 9 Arms with friction or pneumatic brakes

<b>9</b>	<p>Indirect lighting of the extension arm (extension arm length 800 and 1000 mm) COLUMN SPRING (extension arm length 1000, 1200, 1400 and 1600 mm)</p>
<p> an update:</p> <p style="padding-left: 40px;">See section 6.6.8 of this manual.</p> <ul style="list-style-type: none"> <li>- 1 extension arm lighting (600 mm long, input voltage 12 V DC)</li> <li>- 3 sealing plugs at the top of the extension arm</li> <li>- 1 basic stand with LED and connection cable</li> <li>- 1 electrical signal cable, with connectors at both ends</li> <li>- 1 pouch</li> <li>- 2 countersunk screws M4 x 16 mm - DIN EN ISO 10642</li> </ul> <p>- (optional) 1 set of telescopic magnet pick-up tools</p>	

# COLUMN

Installation manual



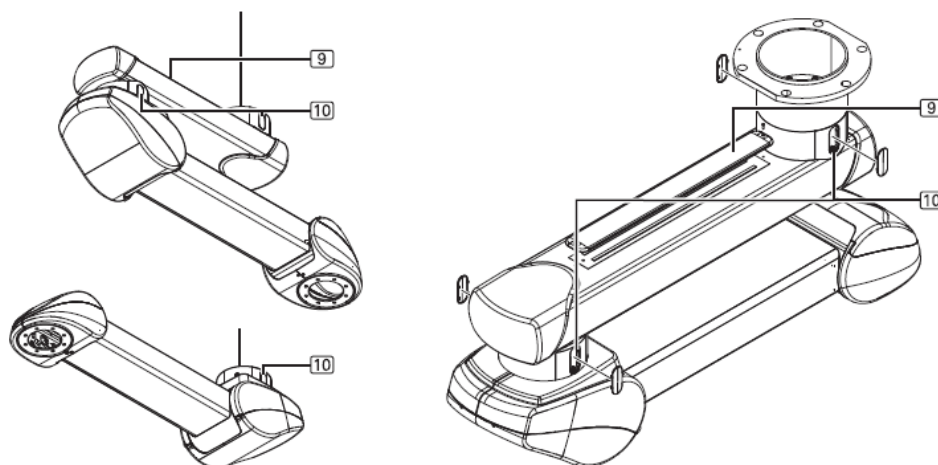



Fig. 10 Electromagnetically braked arms

<b>9</b>	Indirect lighting of the extension arm
<p>COLUMN (extension arm length 800, 1000 and 1200 mm)            INVERTED COLUMN (extension arm length 800, 1000 and 1200 mm)            COLUMN XL and XXL (extension arm length 1000, 1200, 1400 and 1600 mm)            COLUMN MOTOR (extension arm length 800, 1000 and 1200 mm)            COLUMN MOTOR XL (extension arm length 1000, 1200, 1400, 1600 mm)            COLUMN SPRING (extension arm length 1000, 1200, 1400 and 1600 mm)</p>	
<p>For an update:</p>  <p>See section 6.6.8 of this manual.</p> <ul style="list-style-type: none"> <li>- 1 extension arm lighting (600 mm long, input voltage 12 V DC)</li> <li>- 3 sealing plugs at the top of the extension arm</li> <li>- 1 basic stand with LED and connection cable</li> <li>- 1 electrical signal cable, with connectors at both ends</li> <li>- 1 pouch</li> <li>- 2 countersunk screws M4 x 16 mm - DIN EN ISO 10642</li> </ul>	
<b>10</b>	Brake indicators (for single and double arm extensions):
<p>For an update:</p>  <p>See section 6.6.9 of this manual.</p> <ul style="list-style-type: none"> <li>- 2 / 4 plastic covers (pre-assembled)</li> <li>- 2 / 4 lighting boards (12 V DC supply voltage) (2 lighting boards each connected in series to the 24 V DC source)</li> <li>- 2/4 power cables</li> </ul> <p>- (optional) 1 set of telescopic magnet pick-up tools</p>	

### 6.3. Additional instructions

The following parts should be available:

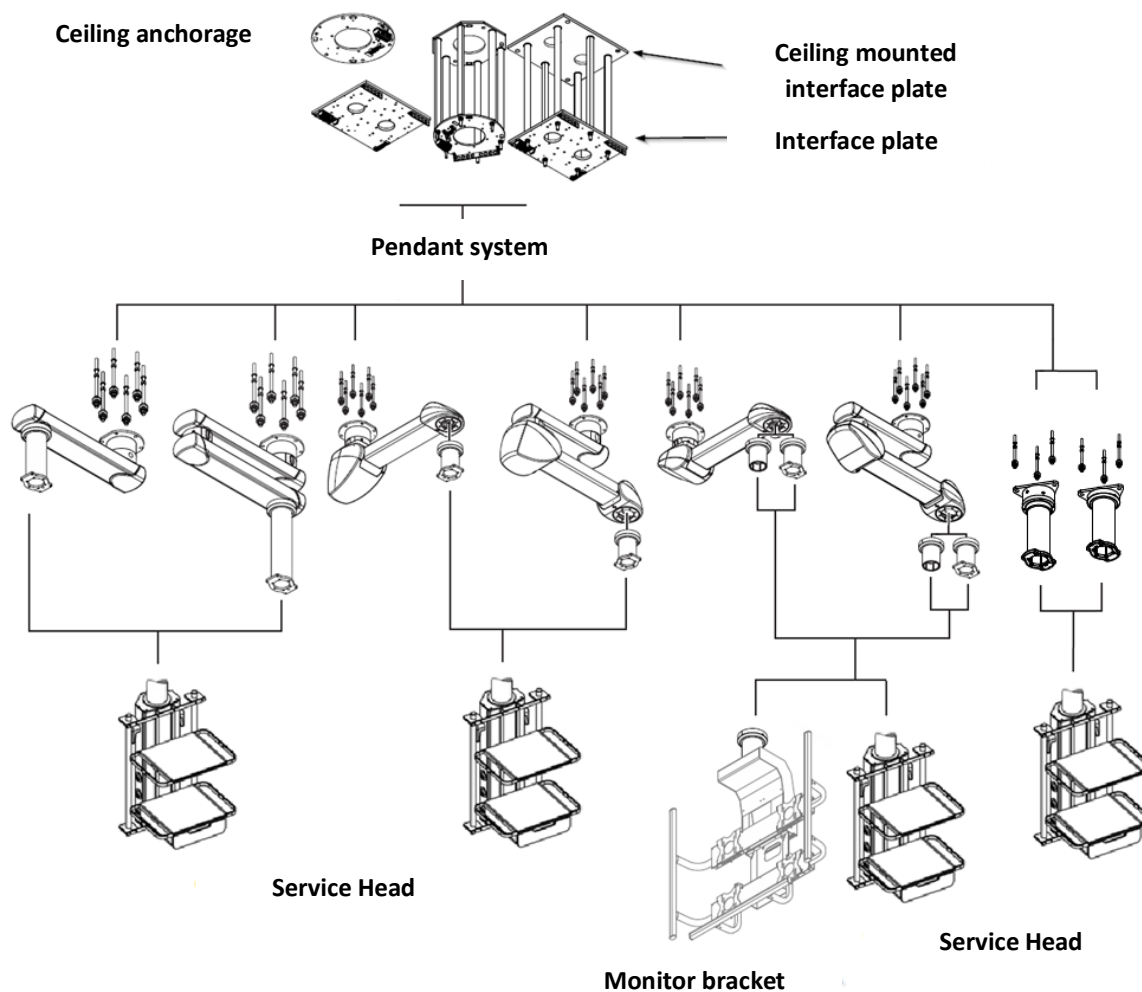

Fig. 11 Outline of instructions

### 6.4. Loading data

The data required for the calculation of the ceiling load are given in the following tables. When mounting the suspension system, the vertical weight force of the intermediate ceiling assembly (the values correspond to the maximum load) must be added to the corresponding values of the suspension system to determine the ceiling load.



Prescribed safety factors in individual regions

This must be taken into account when calculating the maximum load data!



The table shows the values for the maximum permissible load capacity of the suspension system, single version. The load data of a tandem version can be calculated from the sum of the individual ones. Picture on the right in figure 12.

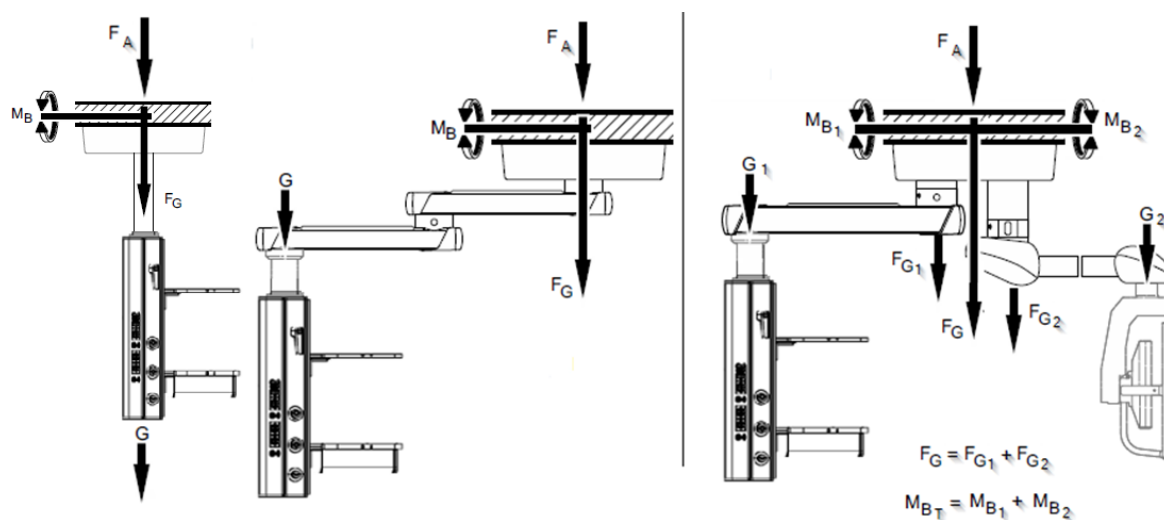

Fig. 12 Load calculation scheme

#### 6.4.1. COLUMN ROTATION

Sliding bearing version CD	Weight (FG) [N] [N]	Weight (FA) [N] Anchor kit	Max. bending moment MB [Nm] [Nm] [Nm]	Load G [kg]
Length 120mm - 1800mm	4074	1300	747	385
Roller bearing version RR	Weight (FG) [N] [N]	Weight (FA) [N] Anchor kit	Max. bending moment MB [Nm] [Nm] [Nm]	Load G [kg]
Length 220mm - 1800mm	4074	1300	747	385

#### 6.4.2. COLUMN AIR

Single arm versions	Weight (FG) [N] [N]	Weight (FA) [N] Anchor kit	Max. bending moment MB [Nm] [Nm] [Nm]	Load G [kg]
Extension arm 600mm	6017	1300	3457	580
Extension arm 800mm	4477	1300	3405	420
Extension arm 1000mm	3525	1300	3300	320
Double arm versions	Weight (FG) [N] [N]	Weight (FA) [N] Anchor kit	Max. bending moment MB [Nm] [Nm] [Nm]	Load G [kg]
Extension arm 600mm / 600mm	3116	1300	3286	260
Extension arm 600mm / 800mm	2753	1300	3288	220
Extension arm 800mm / 600mm	2753	1300	3322	220

Extension arm 800mm / 800mm	2391	1300	3173	180
Extension arm 600mm / 1000mm	2391	1300	3140	180
Extension arm 800mm / 1000mm	2126	1300	3050	150
Extension arm 1000mm / 600mm	2391	1300	3206	180
Extension arm 1000mm / 800mm	2126	1300	3083	150

#### 6.4.3. COLUMN AIRPLUS AND COLUMN FRICTION

Single arm versions	Weight (FG) [N] [N]	Weight (FA) [N] Anchor kit	Max. bending moment MB [Nm] [Nm] [Nm]	Load G [kg]
Extension arm 600mm	6605	1300	3810	640
Extension arm 800mm	4967	1300	3758	470
Extension arm 1000mm	4016	1300	3790	370
Double arm versions	Weight (FG) [N] [N]	Weight (FA) [N] Anchor kit	Max. bending moment MB [Nm] [Nm] [Nm]	Load G [kg]
Extension arm 600mm / 600mm	3508	1300	3757	300
Extension arm 600mm / 800mm	3146	1300	3838	260
Extension arm 800mm / 600mm	3146	1300	3871	260
Extension arm 800mm / 800mm	2783	1300	3801	220
Extension arm 600mm / 1000mm	2783	1300	3768	220
Extension arm 800mm / 1000mm	2518	1300	3756	190
Extension arm 1000mm / 600mm	2783	1300	3834	220
Extension arm 1000mm / 800mm	2518	1300	3789	190
Extension arm 1000mm / 1000mm	2352	1300	3829	170

## 6.4.4. COLUMN AND COLUMN INVERTED

Single arm versions	Weight (FG) [N] [N]	Weight (FA) [N] Anchor kit	Max. bending moment MB [Nm] [Nm] [Nm]	Load G [kg]
Extension arm 600mm	6834	1300	3815	640
Extension arm 800mm	5196	1300	3764	470
Extension arm 1000mm	4245	1300	3739	370
Extension arm 1200mm	3587	1300	3680	300

Double arm versions	Weight (FG) [N] [N]	Weight (FA) [N] Anchor kit	Max. bending moment MB [Nm] [Nm] [Nm]	Load G [kg]
Extension arm 600mm / 600mm	3737	1300	3761	300
Extension arm 600mm / 800mm	3374	1300	3842	260
Extension arm 600mm / 1000mm	3011	1300	3773	220
Extension arm 600mm / 1200mm	2746	1300	3728	190
Extension arm 800mm / 600mm	3374	1300	3875	260
Extension arm 800mm / 800mm	3011	1300	3806	220
Extension arm 800mm / 1000mm	2747	1300	3762	190
Extension arm 800mm / 1200mm	2580	1300	3802	170
Extension arm 1000mm / 600mm	3012	1300	3839	220
Extension arm 1000mm / 800mm	2747	1300	3795	190
Extension arm 1000mm / 1000mm	2580	1300	3835	170
Extension arm 1000mm / 1200mm	2413	1300	3803	150
Extension arm 1200mm / 600mm	2747	1300	3828	190
Extension arm 1200mm / 800mm	2580	1300	3868	170
Extension arm 1200mm / 1000mm	2413	1300	3836	150
Extension arm 1200mm / 1200mm	2247	1300	3731	130

## 6.4.5. COLUMN XL

Single arm versions	Weight (FG) [N] [N]	Weight (FA) [N] Anchor kit	Max. bending moment MB [Nm] [Nm] [Nm]	Load G [kg]
Extension arm 600mm	10315	1300	5953	1000
Extension arm 800mm	8598	1300	6544	820
Extension arm 1000mm	6980	1300	6537	650

Extension arm 1200mm	5950	1300	6697	540
Extension arm 1400mm	5410	1300	6886	480
Extension arm 1600mm	4674	1300	6653	400

Double arm versions	Weight (FG) [N] [N]	Weight (FA) [N] Anchor kit	Max. bending moment M <sub>B</sub> [Nm] [Nm] [Nm]	Load G [kg]
Extension arm 600mm / 600mm	5943	1300	6488	530
Extension arm 600mm / 800mm	5384	1300	6746	470
Extension arm 800mm / 600mm	5404	1300	6795	470
Extension arm 800mm / 800mm	4648	1300	6509	390
Extension arm 600mm / 1000mm	4433	1300	6146	370
Extension arm 800mm / 1000mm	4089	1300	6268	330
Extension arm 1000mm / 600mm	4668	1300	6562	390
Extension arm 600mm / 1200mm	3776	1300	5689	300
Extension arm 1000mm / 800mm	4109	1300	6321	330
Extension arm 1200mm / 600mm	4128	1300	6378	330
Extension arm 800mm / 1200mm	3825	1300	6386	300
Extension arm 1000mm / 1000mm	3844	1300	6439	300
Extension arm 1000mm / 1200mm	3579	1300	6446	270
Extension arm 1200mm / 800mm	3864	1300	6496	300
Extension arm 1200mm / 1000mm	3599	1300		270
Extension arm 1200mm / 1200mm	3334	1300	6397	240
Extension Arm 1400mm / 600mm	3883	1300	6556	300
Extension arm 1400mm / 800mm	3618	1300	6563	270
Extension arm 1400mm / 1000mm	3354	1300	6458	240
Extension arm 1400mm / 1200mm	2991	1300	5986	200
Extension arm 1600mm / 600mm	3638	1300	6627	270
Extension arm 1600mm / 800mm	3373	1300	6522	240
Extension arm 1600mm / 1000mm	3010	1300	6050	200

## 6.4.6. COLUMN XXL

Double arm versions	Weight (FG) [N] [N]	Weight (FA) [N] Anchor kit	Max. bending moment MB [Nm] [Nm] [Nm]	Load G [kg]
Extension arm 600mm / 600mm	6196	1300	6719	540
Extension arm 600mm / 800mm	5656	1300	7023	480
Extension arm 800mm / 600mm	5656	1300	7074	480
Extension arm 800mm / 800mm	4921	1300	6839	400
Extension arm 600mm / 1000mm	4921	1300	6788	400
Extension arm 800mm / 1000mm	4381	1300	6653	340
Extension arm 1000mm / 600mm	4921	1300	6890	400
Extension arm 600mm / 1200mm	4381	1300	6602	340
Extension arm 1000mm / 800mm	4381	1300	6704	340
Extension arm 1200mm / 600mm	4381	1300	6755	340
Extension arm 800mm / 1200mm	4136	1300	6830	310
Extension arm 800mm / 1400mm	3891	1300	6899	280
Extension arm 1000mm / 1000mm	4136	1300	6881	310
Extension arm 1000mm / 1200mm	3891	1300	6950	280
Extension arm 1000mm / 1400mm	3645	1300	6911	250
Extension arm 1000mm / 1600mm	3302	1300	6510	210
Extension arm 1200mm / 800mm	4136	1300	6932	310
Extension arm 1200mm / 1000mm	3891	1300	7001	280
Extension arm 1200mm / 1200mm	3645	1300	6963	250
Extension Arm 1200mm / 1400mm	3302	1300	6561	210
Extension Arm 1400mm / 600mm	4136	1300	6983	310
Extension Arm 1400mm / 800mm	3891	1300	7053	280
Extension Arm 1400mm / 1000mm	3645	1300	7014	250
Extension Arm 1400mm / 1200mm	3302	1300	6612	210
Extension arm 1600mm / 600mm	3891	1300	7104	280
Extension arm 1600mm / 800mm	3645	1300	7065	250
Extension arm 1600mm / 1000mm	3302	1300	6663	210

## 6.4.7. COLUMN MOTOR, COLUMN MOTOR XL, COLUMN MOTOR XXL

Single arm versions	Weight (FG) [N] [N]	Weight (FA) [N] Anchor kit	Max. bending moment MB [Nm] [Nm] [Nm]	Load G [kg]
COLUMN MOTOR	2195	1300	1550	150
COLUMN MOTOR XL	2784	1300	2150	210
COLUMN MOTOR XXL	3176	1300	2550	250
Double arm versions (Extension Arm + COLUMN MOTOR)	Weight (FG) [N] [N]	Weight (FA) [N] Anchor kit	Max. bending moment MB [Nm] [Nm] [Nm]	Load G [kg]
Extension arm 600mm	2387	1300	2800	150
Extension arm 800mm	2417	1300	3250	150
Extension arm 1000mm	2446	1300	3700	150
Extension arm 1200mm	2378	1300	3900	140
Double arm versions (Extension Arm + COLUMN MOTOR XL)	Weight (FG) [N] [N]	Weight (FA) [N] Anchor kit	Max. bending moment MB [Nm] [Nm] [Nm]	Load G [kg]
Extension arm 600mm	2975	1300	3750	210
Extension arm 800mm	2711	1300	3750	180
Extension arm 1000mm	2544	1300	3850	160
Extension arm 1200mm	2376	1300	3900	140
Double arm versions (Extension arm + COLUMN MOTOR XXL)	Weight (FG) [N] [N]	Weight (FA) [N] Anchor kit	Max. bending moment MB [Nm] [Nm] [Nm]	Load G [kg]
Extension arm 600mm	3609	1300	4400	250
Extension arm 800mm	3658	1300	5050	250
Extension arm 1000mm	3707	1300	5700	250
Extension arm 1200mm	3756	1300	6400	250
Extension arm 1400mm	3707	1300	6800	240
Extension arm 1600mm	3364	1300	6450	200

## 6.4.8. COLUMN MOTOR AIRPLUS, COLUMN MOTOR FRICTION

Single arm versions	Weight (FG) [N] [N]	Weight (FA) [N] Anchor kit	Max. bending moment MB [Nm] [Nm] [Nm]	Load G [kg]
COLUMN MOTOR	2195	1300	1550	150
COLUMN MOTOR XL	2784	1300	2150	210
COLUMN MOTOR XXL	3176	1300	2550	250
Double arm versions (Extension Arm + COLUMN MOTOR)	Weight (FG) [N] [N]	Weight (FA) [N] Anchor kit	Max. bending moment MB [Nm] [Nm] [Nm]	Load G [kg]
Extension arm 600mm	2387	1300	2800	150
Extension arm 800mm	2417	1300	3250	150
Extension arm 1000mm	2446	1300	3700	150
Double arm versions (Extension Arm + COLUMN MOTOR XL)	Weight (FG) [N] [N]	Weight (FA) [N] Anchor kit	Max. bending moment MB [Nm] [Nm] [Nm]	Load G [kg]
Extension arm 600mm	2975	1300	3750	210
Extension arm 800mm	2711	1300	3750	180
Extension arm 1000mm	2544	1300	3850	160

## 6.4.9. COLUMN SPRING AIRPLUS, COLUMN SPRING FRICTION

Single arm versions	Weight (FG) [N] [N]	Weight (FA) [N] Anchor kit	Max. bending moment MB [Nm] [Nm] [Nm]	Load G [kg]
COLUMN SPRING	2578	1300	1900	180
Double Arm Versions (Extension Arm + COLUMN SPRING)	Weight (FG) [N] [N]	Weight (FA) [N] Anchor kit	Max. bending moment MB [Nm] [Nm] [Nm]	Load G [kg]
Extension arm 600mm	2770	1300	3450	180
Extension arm 800mm	2701	1300	3800	170
Extension arm 1000mm	2535	1300	3900	150
Extension arm 1200mm (Only for CEMOR monitor bracket)	2368	1300	3950	130

## 6.4.10. COLUMN SPRING E-BRAKE

Single arm versions	Weight (FG) [N] [N]	Weight (FA) [N] Anchor kit	Max. bending moment MB [Nm] [Nm] [Nm]	Load G [kg]
COLUMN SPRING	2578	1300	1900	180
Double arm versions (Extension arm + COLUMN SPRING)	Weight (FG) [N] [N]	Weight (FA) [N] Anchor kit	Max. bending moment MB [Nm] [Nm] [Nm]	Load G [kg]
Extension arm 600mm	2770	1300	3450	180
Extension arm 800mm	2701	1300	3800	170
Extension arm 1000mm	2535	1300	3900	150
Extension arm 1200mm	2368	1300	3950	130
Double arm versions (XL Extension Arm + COLUMN SPRING)	Weight (FG) [N] [N]	Weight (FA) [N] Anchor kit	Max. bending moment MB [Nm] [Nm] [Nm]	Load G [kg]
Extension arm XL 600mm	2948	1300	3450	180
Extension arm XL 800mm	2997	1300	4000	180
Extension arm XL 1000mm	3046	1300	4550	180
Extension arm XL 1200mm	3095	1300	5100	180
Extension arm XL 1400mm	3144	1300	5650	180
Extension arm XL 1600mm	3193	1300	6250	180

## 6.4.11. Service head and accessories

In this section the weights for the different service heads attachable to the pendant system are given without taking into account the electrical, communication and gas hoses. These weights must be taken into account when checking the payload given in this chapter for the different configurations of the pendant system in addition to any accessories that may be attached to the service heads.

TDSHV vertical service head (500mm) .....	14kg
TDSHV vertical service head (750mm) .....	18kg
TDSHV vertical service head (1000mm) .....	21kg
TDSHV vertical service head (1250mm) .....	25kg
TDSHV vertical service head (1500mm) .....	29kg
TDSHH horizontal service head (600mm) .....	18kg
Horizontal service head TDSHH (750mm) .....	20kg



Horizontal service head TDSHH (1000mm) .....	23kg
Tray on vertical service head .....	9kg
Drawer in vertical service head .....	16,5kg
1m 38mm diameter tube set for attachment of accessories.....	3kg
Tray on horizontal service head .....	6kg
Drawer in horizontal service head .....	14kg
Flange assembly for 38mm diameter pipe.....	0,35kg
Stainless steel double technical rail set on 38mm diameter tube (L=500mm) .....	1,6kg
Double technical stainless steel rail set on 38mm diameter tube (L=700mm) .....	2kg
Double technical aluminium rail set on 38mm diameter tube (L=500mm) .....	1,4kg
Double technical aluminium rail set on 38mm diameter tube (L=700mm) .....	1,7kg

## 6.5. Mounting of threaded bolts on the interface plate

### 6.5.1. Installation without false ceiling

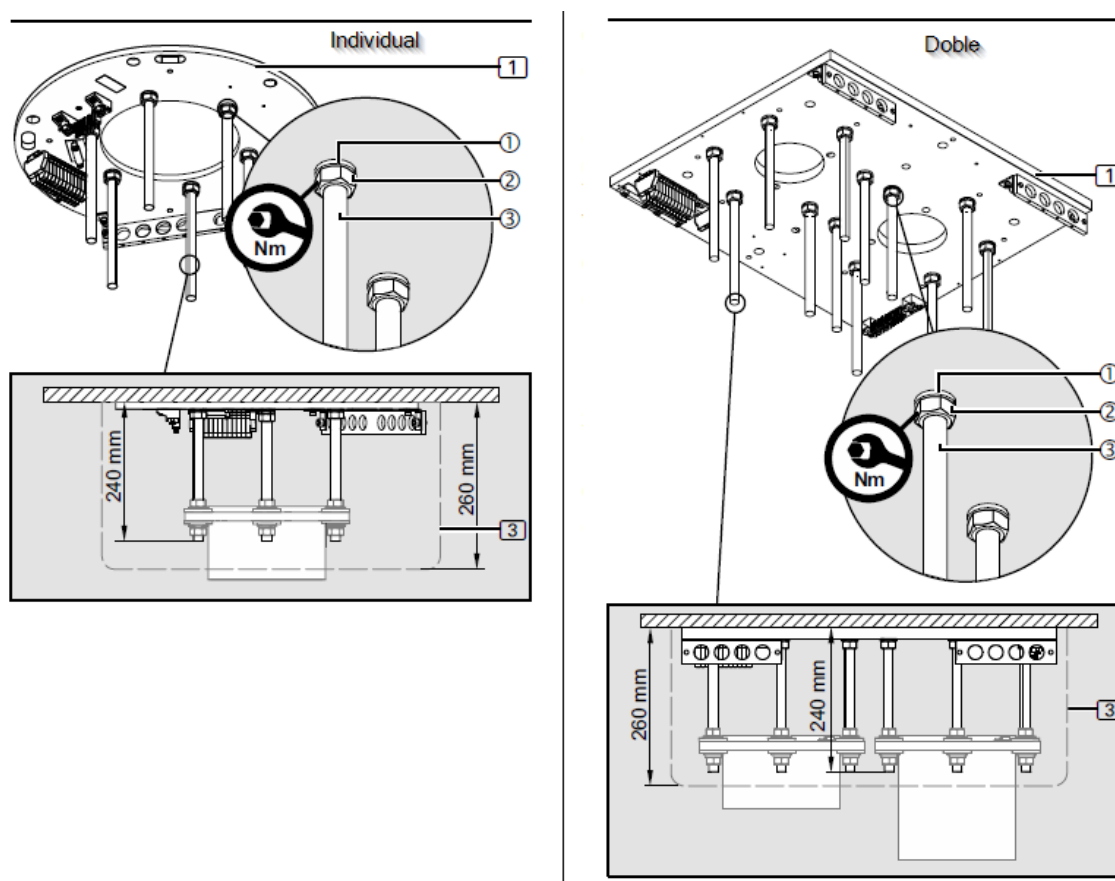

Fig. 13 Mounting of interface plate without false ceiling

- Cut the threaded bolts to length

If an interface plate (1) is mounted on the intended slab or structure, the threaded bolts M16 x 330 mm ③ (6 in the single version, 12 in the double version) must be cut to size.

- The roof trim (3) will later be mounted flush with the roof and covers the flange of the roof tube.
- For the ceiling trim (3), which has a height of 260 mm, the 6/12 M16 x 330 mm threaded bolts ③ must be cut to 240 mm (max. 245 only for COLUMN ROTATION). See Fig. 10.
- Lightly deburr the M16 x 330 mm threaded bolts ① to ensure maximum thread engagement in the interface plate (1).
- Thread 1 M16 hex nut ② each onto the M16 threaded bolts ③ and then fit 1 spring washer ④ each.



If the M16 threaded bolts ③ ③ are not completely screwed in, they may come out of the interface plate (1) and cause the system to fall down.

- Check that the shortened M16 threaded bolts ③ are securely fastened at the correct distance from each other and fully screwed into the interface plate 1.



The M16 hex nuts ② must be tightened to 195 Nm.

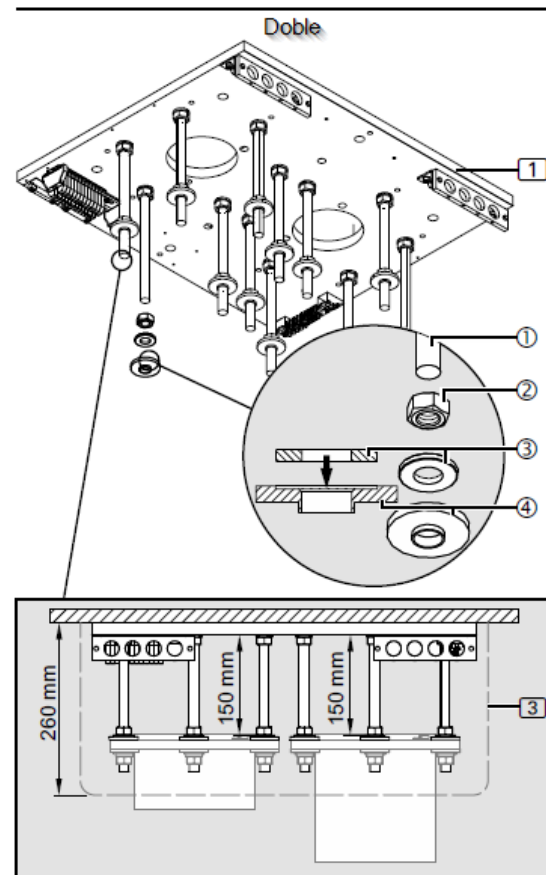
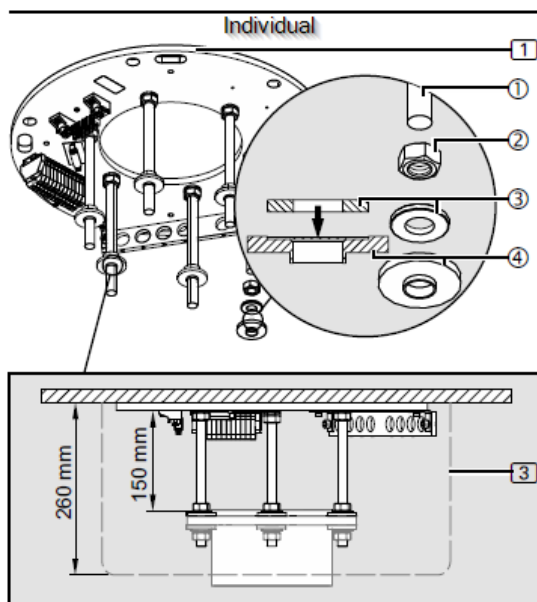

Fig. 14 Fitting of the upper insulation to the threaded bolts without a false ceiling

- For each M16 threaded bolt ① screw an M16 hexagon nut ② onto the M16 threaded bolts ①.

The M16 hexagon nuts ② (6 for single version, 12 for double version) must be mounted on the M16 threaded bolts ① at exactly the right distance from each other.

- Adjust the distance between the M16 hex nuts ② and the interface plate from 1 to 150mm.
- Using a digital spirit level, align the M16 hex nuts ② horizontally.
- Fit 1 flat washer with an outer diameter of 34 mm ③.
- Place 1 plastic insulating disc ④ (as shown in figure 11) in such a way that the flat washer with an outer diameter of 34 mm ③ sits on the plastic insulating disc ④.
- Secure the plastic insulating disc ④ to the M16 threaded bolts ① with adhesive or elastic tape.

#### 6.5.2. Mounting with false ceiling

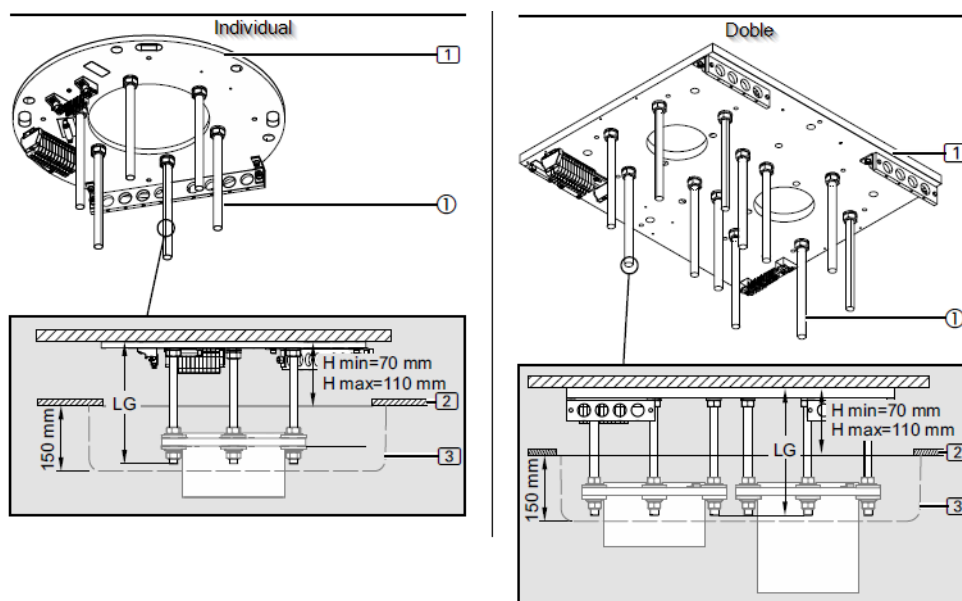

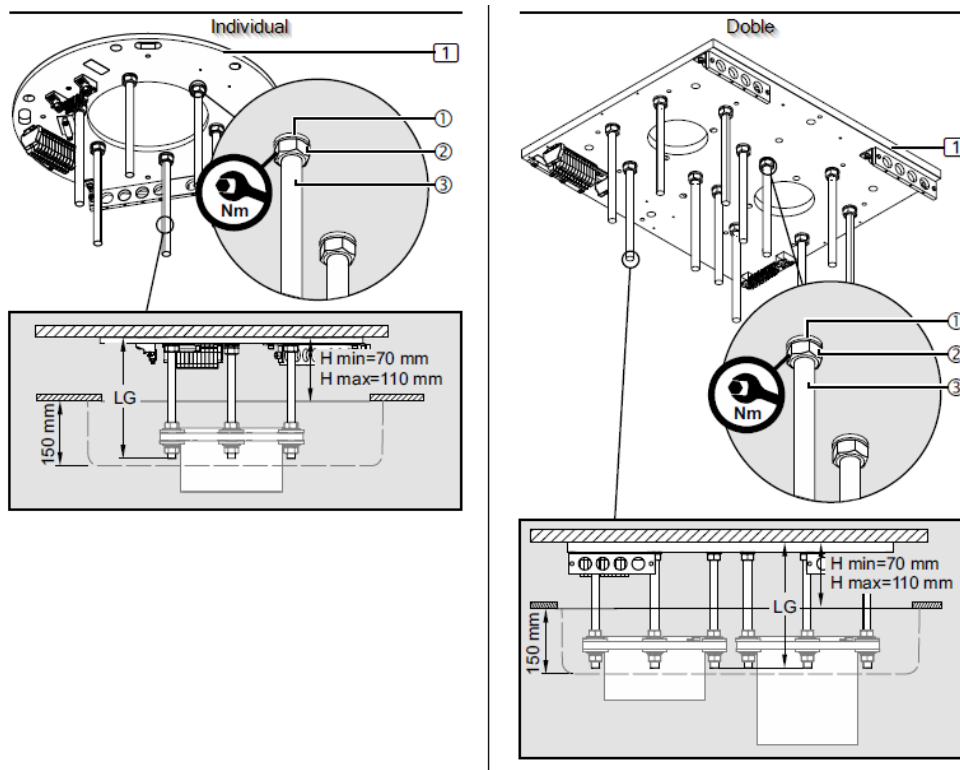

Fig. 15 Installation of interface plate with suspended ceiling

- Cut the threaded bolts to length

If an interface plate (1) is mounted on the intended slab or structure, the threaded bolts M16 x 330 mm (3) (6 in the single version, 12 in the double version) must be cut to size.

- The roof trim (3) will later be mounted flush with the roof and covers the roof pipe flange.
- The required length of the threaded bolts M16 x 330 mm (1) depends on the distance H: from the roof to the lower edge of the intermediate ceiling 2.
- Please note the minimum and maximum length of the threaded bolts M16 x 330 mm (1).
- For the ceiling trim (3), which has a height of 150 mm, the 6/12 M16 x 330 mm threaded bolts (3) must be cut as shown in Fig. 12.
- To determine the LG length of the threaded bolts (1),  $LG = H + 135\text{mm}$  (min. 205mm / max. 245mm)
- Lightly deburr the M16 x 330 mm threaded bolts (1) to ensure maximum thread engagement in the interface plate (1).
- Thread 1 M16 hex nut (2) each onto the M16 threaded bolts (3) and then fit 1 spring washer (1) each.



If the M16 threaded bolts (3) are not completely screwed in, they may come out of the interface plate (1) and cause the system to fall down.

- Check that the shortened M16 threaded bolts (3) are securely fastened at the correct distance from each other and fully screwed into the interface plate 1.



The M16 hex nuts (2) must be tightened to 195 Nm.

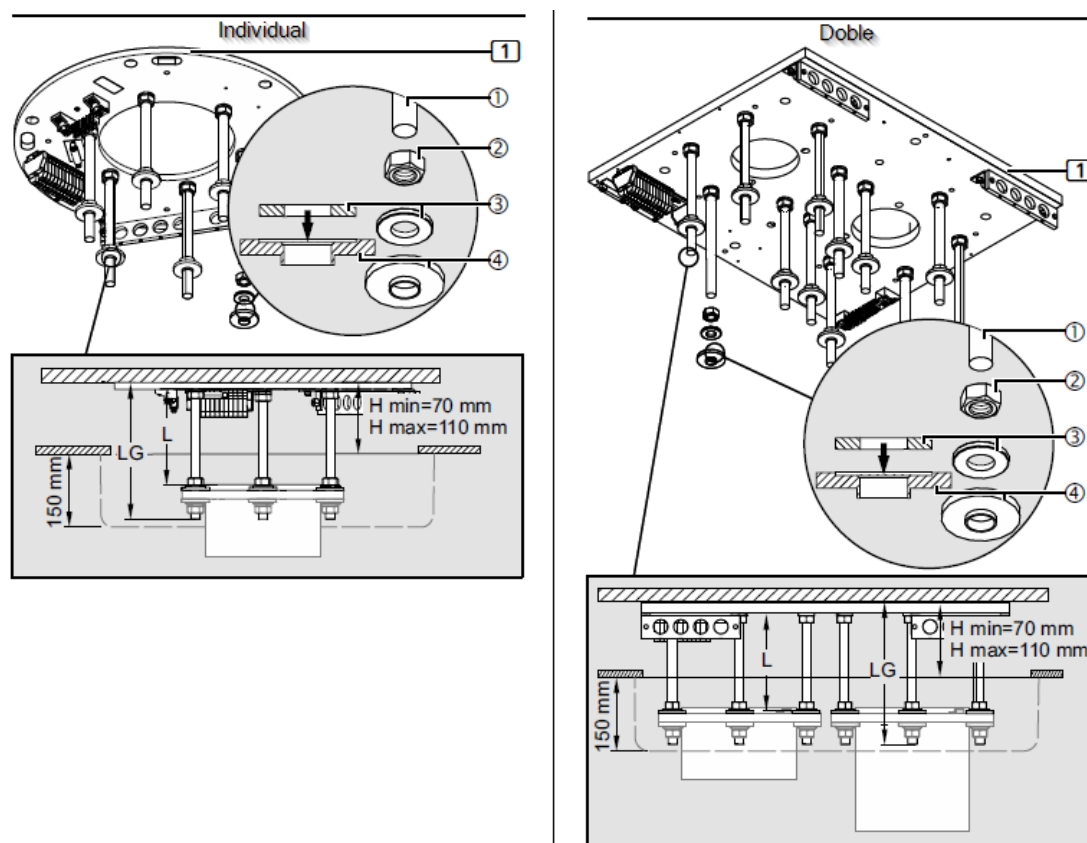

Fig. 16 Installation of the upper insulation to the threaded bolts without false ceilings

- For each M16 threaded bolt (1) screw an M16 hexagon nut (2) onto the M16 threaded bolts (1).

The M16 hexagon nuts (2) (6 for single version, 12 for double version) must be mounted on the M16 threaded bolts (1) at exactly the right distance from each other.

- Set the distance between the M16 hex nuts (2) and the interface plate from 1 to  $L = LG - 95$  mm (min. 110 mm / 150 mm).
- Screw the hexagon nuts M16(2) onto the M16 threaded bolts (1) at the calculated distance L.
- Using a digital spirit level, align the M16 hex nuts (2) horizontally.

- Fit 1 flat washer with an outer diameter of 34 mm (3).
- Place 1 plastic insulating disc (4) (as shown in figure 13) in such a way that the flat washer with an outer diameter of 34 mm (3) sits on the plastic insulating disc (4).
- Secure the plastic insulating disc (4) to the M16 threaded bolts (1) with adhesive or elastic tape.

### 6.5.3. Mounting of interface plate on the false ceiling bracket

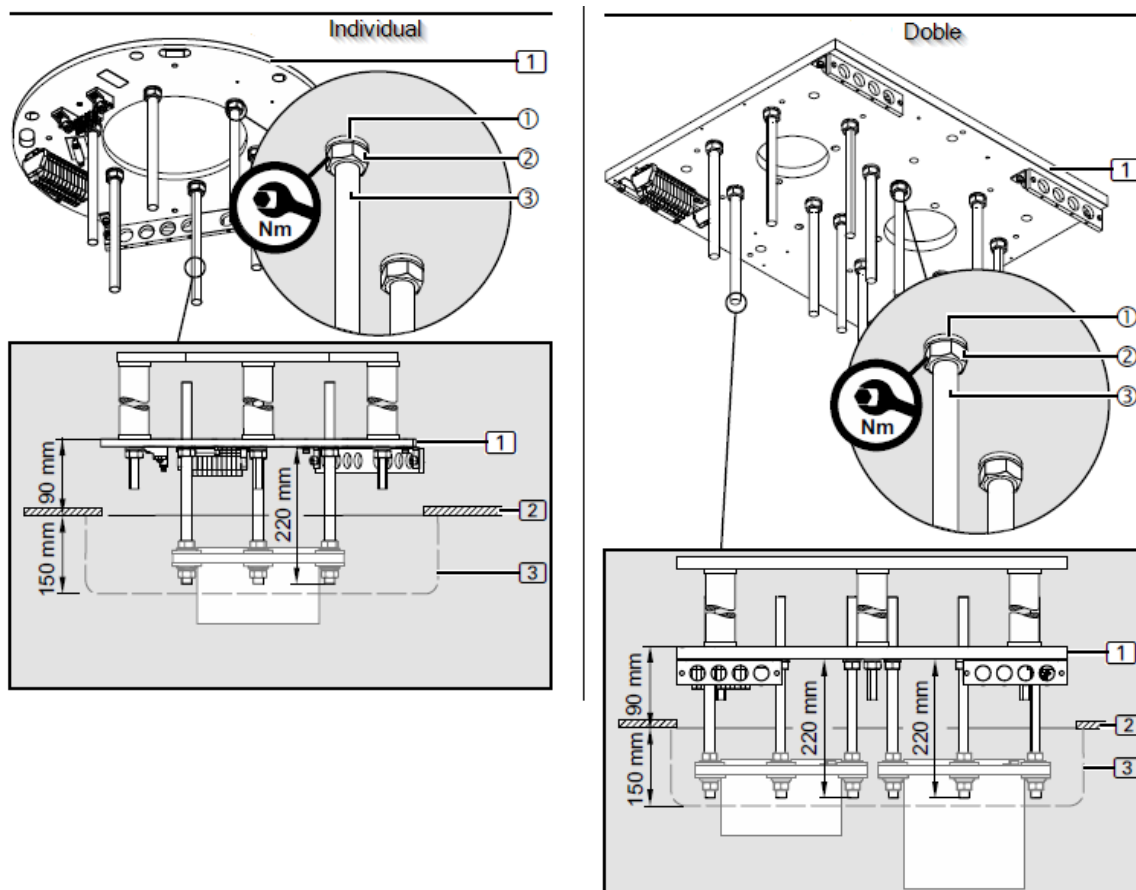

Fig. 17 Mounting of interface plate with false ceiling

The threaded bolts M16 x 330 mm (3) (6 for single version, 12 for double version) must protrude from the interface plate (1).



To ensure sufficient strength, the M16 threaded bolts (1) must not exceed a maximum length of 330 mm.

- Screw 1 M16 hex nut (2) each onto the 6/12 M16 x 330 mm threaded bolts (3) and then fit 1 spring ring (1) each.
- All threaded bolts M16 x 330 mm (3) must be completely screwed into the interface plate 1.

The threaded bolts M16 x 330 mm ③ must protrude from the interface plate (1) 220 mm in both the single and double version. In COLUMN ROTATION minimum 130mm and maximum 170mm.

- Check that the shortened M16 threaded bolts ③ are securely fastened at the correct distance from each other and fully screwed into the interface plate 1.



The M16 hex nuts ② must be tightened to 195 Nm.

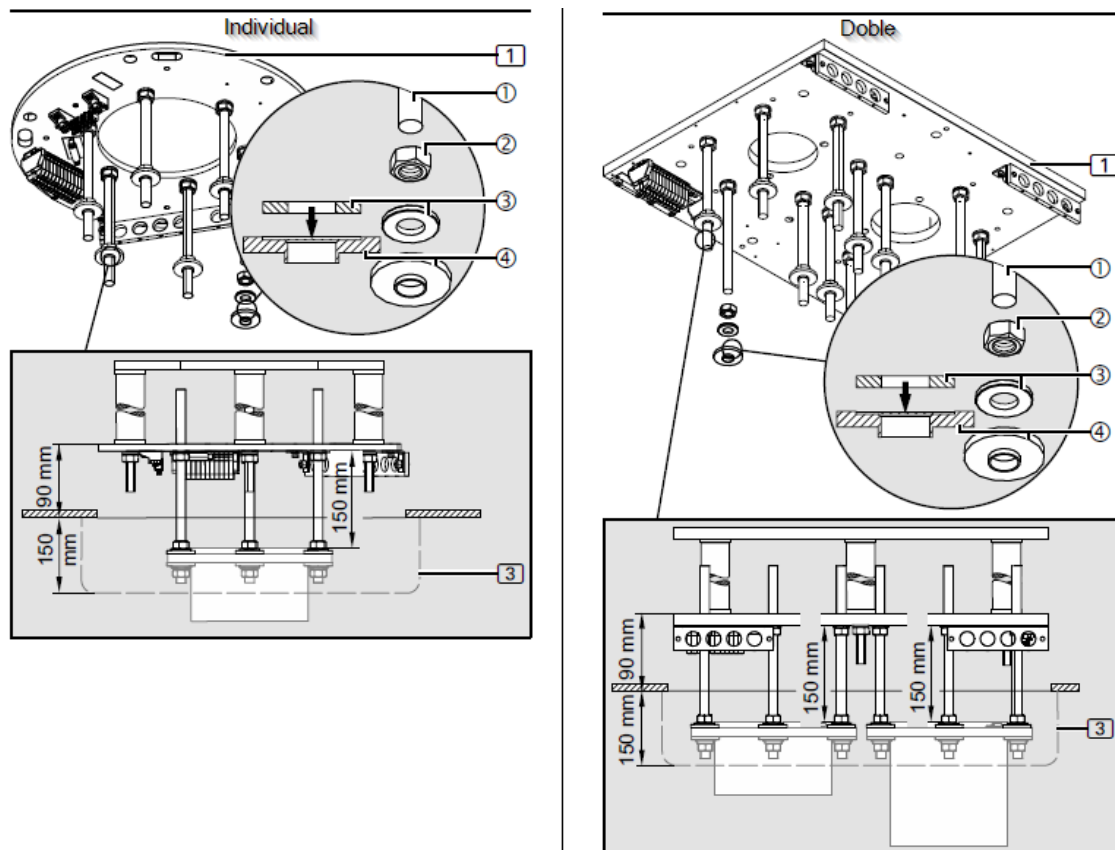

Fig. 18 Fitting the upper insulation to the threaded bolts with false ceilings

- For each M16 threaded bolt ① screw an M16 hexagon nut ② onto the M16 threaded bolts ①.

The M16 hexagon nuts ② (6 for single version, 12 for double version) must be mounted on the M16 threaded bolts ① at exactly the right distance from each other.

- Adjust the distance between the M16 hex nuts ② and the interface plate from 1 to 150mm.
- Screw the hexagon nuts M16 ② onto the M16 threaded bolts ① at the calculated distance L.
- Using a digital spirit level, align the M16 hex nuts ② horizontally.

- Fit 1 flat washer with an outer diameter of 34 mm ③.
- Place 1 plastic insulating disc ④ (as shown in figure 13) in such a way that the flat washer with an outer diameter of 34 mm ③ sits on the plastic insulating disc ④.

## 6.6. Pre-assembly: Ceiling tube (included), drop arm and drop tube

### 6.6.1. Description of components

This section describes the components involved in this manual. For the long roof tube or COLUMN INVERTED variants, the roof tube (6) is included in the scope of delivery as an individual part.

- The roof tube (6) is mounted on the arms (4), (5) (double and single arm variant).
- The following simplified figures illustrate the different configurations without pre-assembled cables.
- The installation is described in the following chapters and is identical for the different versions.
- Please note the different length and number of fixing screws for the different versions.

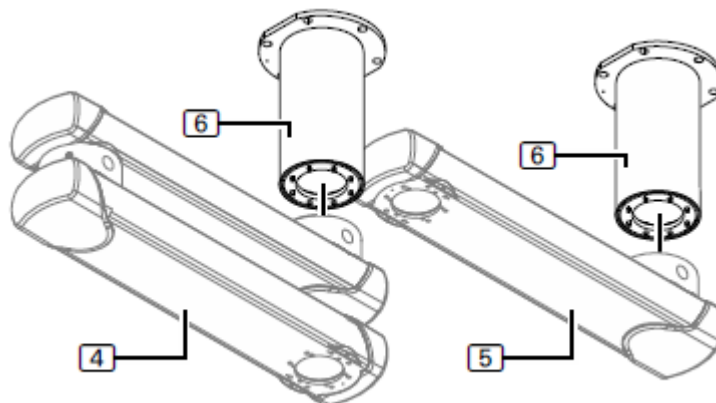

Fig. 19 COLUMN AIR, COLUMN AIRPLUS, COLUMN FRICTION



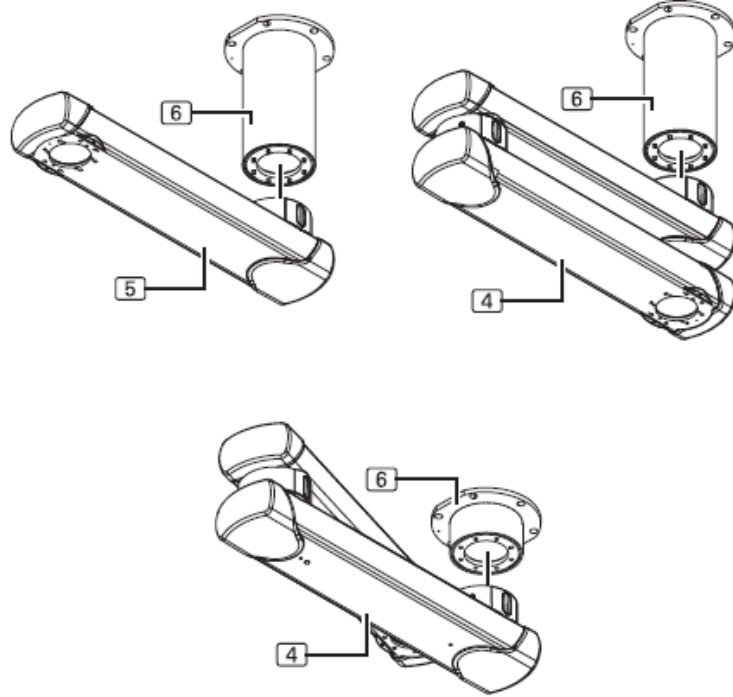

Fig. 20 COLUMN, COLUMN XL, COLUMN XXL

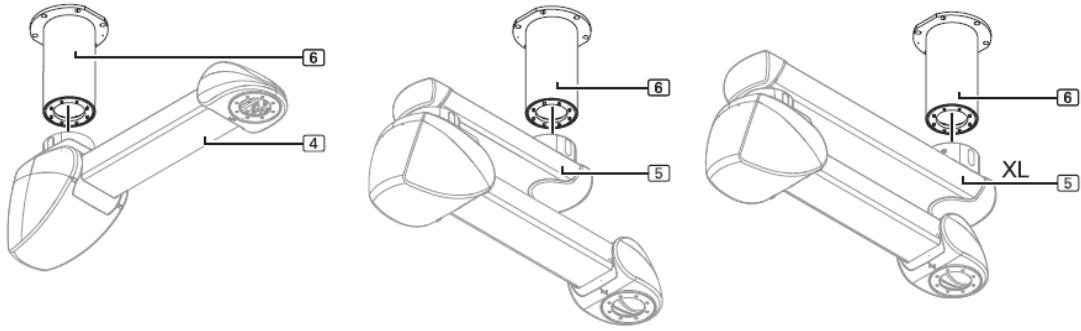

Fig. 21 COLUMN MOTOR, COLUMN MOTOR XL

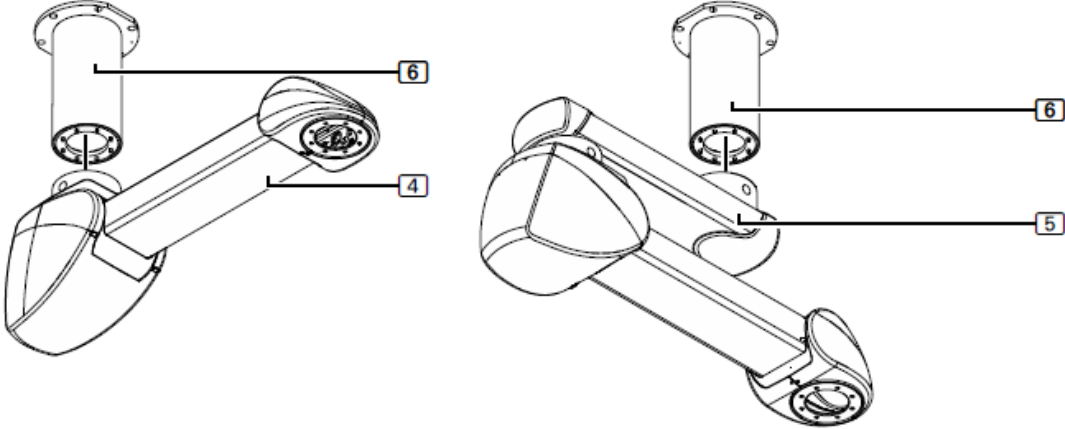

Fig. 22 COLUMN MOTOR AIRPLUS, COLUMN MOTOR FRICTION

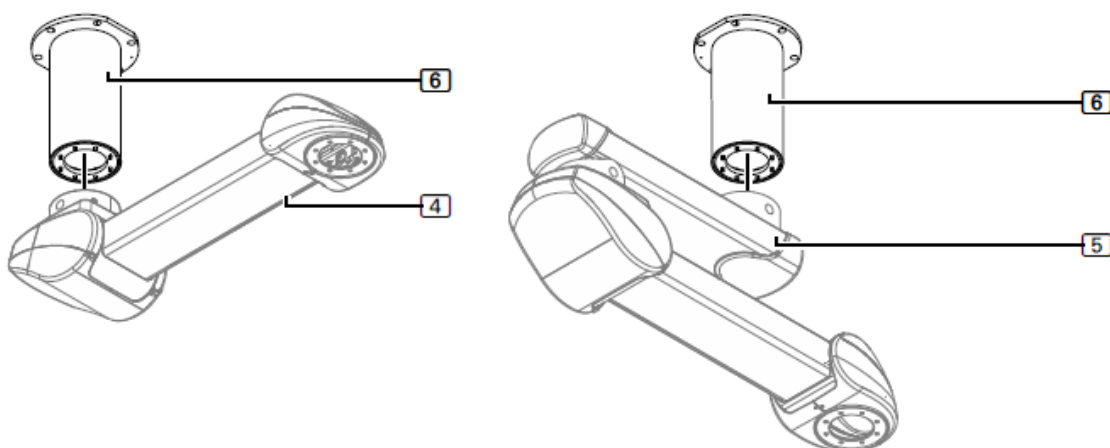

Fig. 23 COLUMN SPRING AIRPLUS, COLUMN SPRING FRICTION

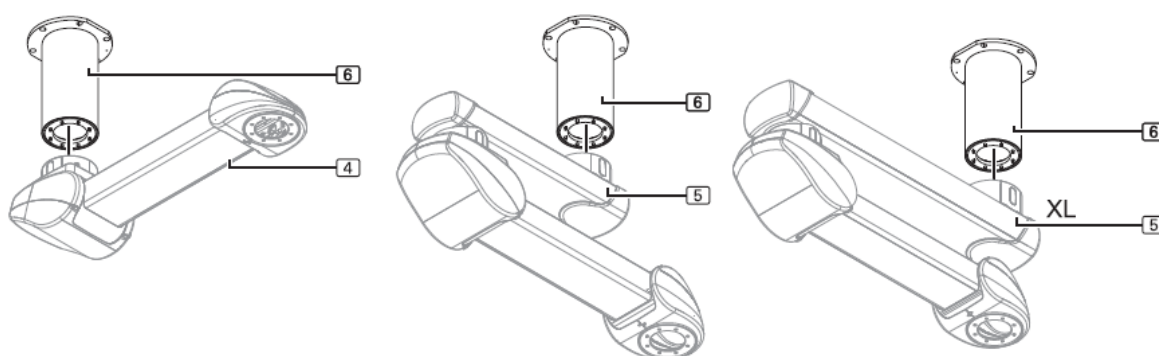

Fig. 24 COLUMN SPRING, COLUMN SPRING XL

- The drop tubes (7) are mounted on the arm (4) for single arm systems and on the arm (5) for double arm systems. This tube will have different heights to adjust the overall height of the service head. A special drop tube variant (8) is available for spring-loaded arms provided with a CEMOR monitor bracket.

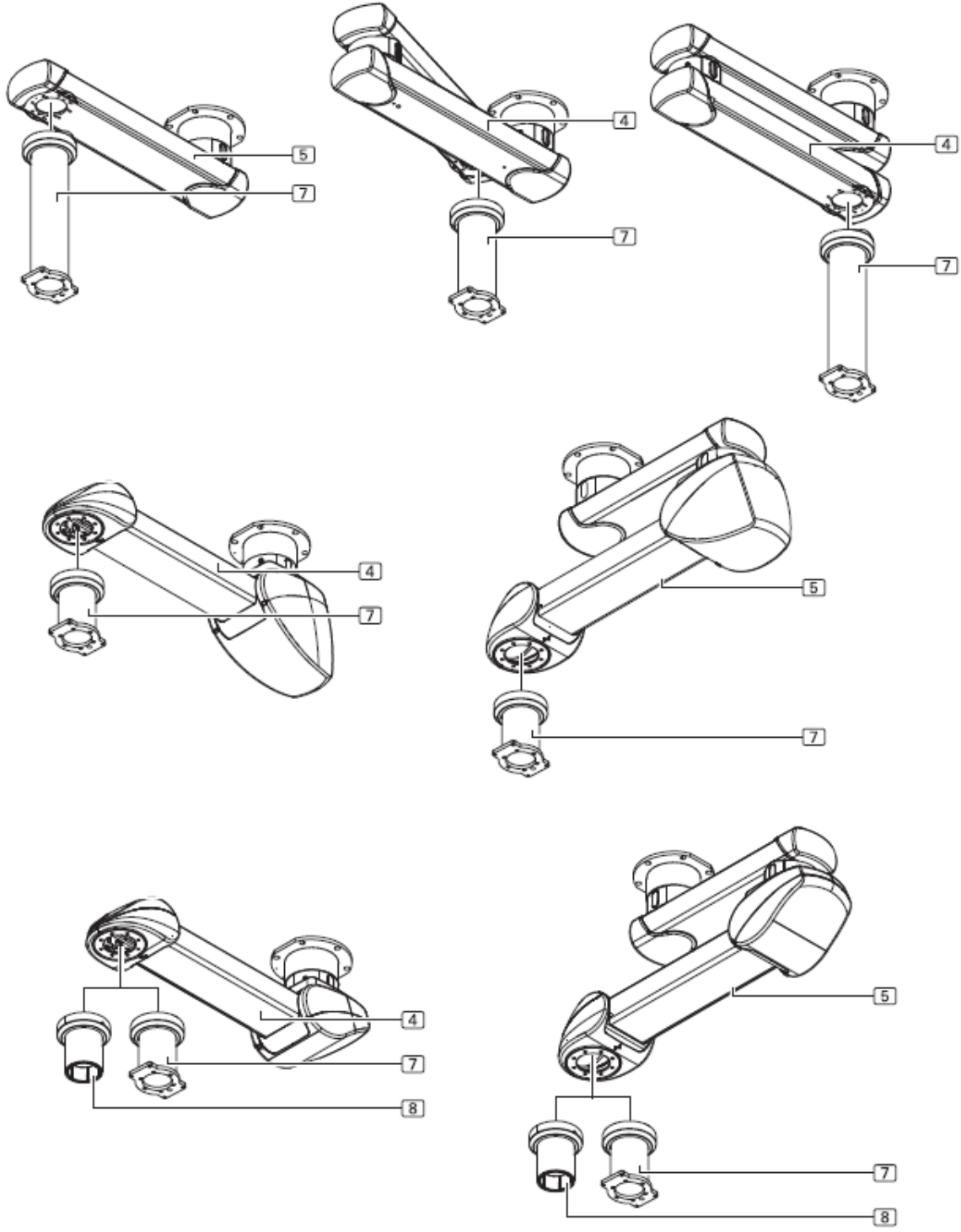

Fig. 25 Drop tubes

## 6.6.2. Ceiling tube mounting

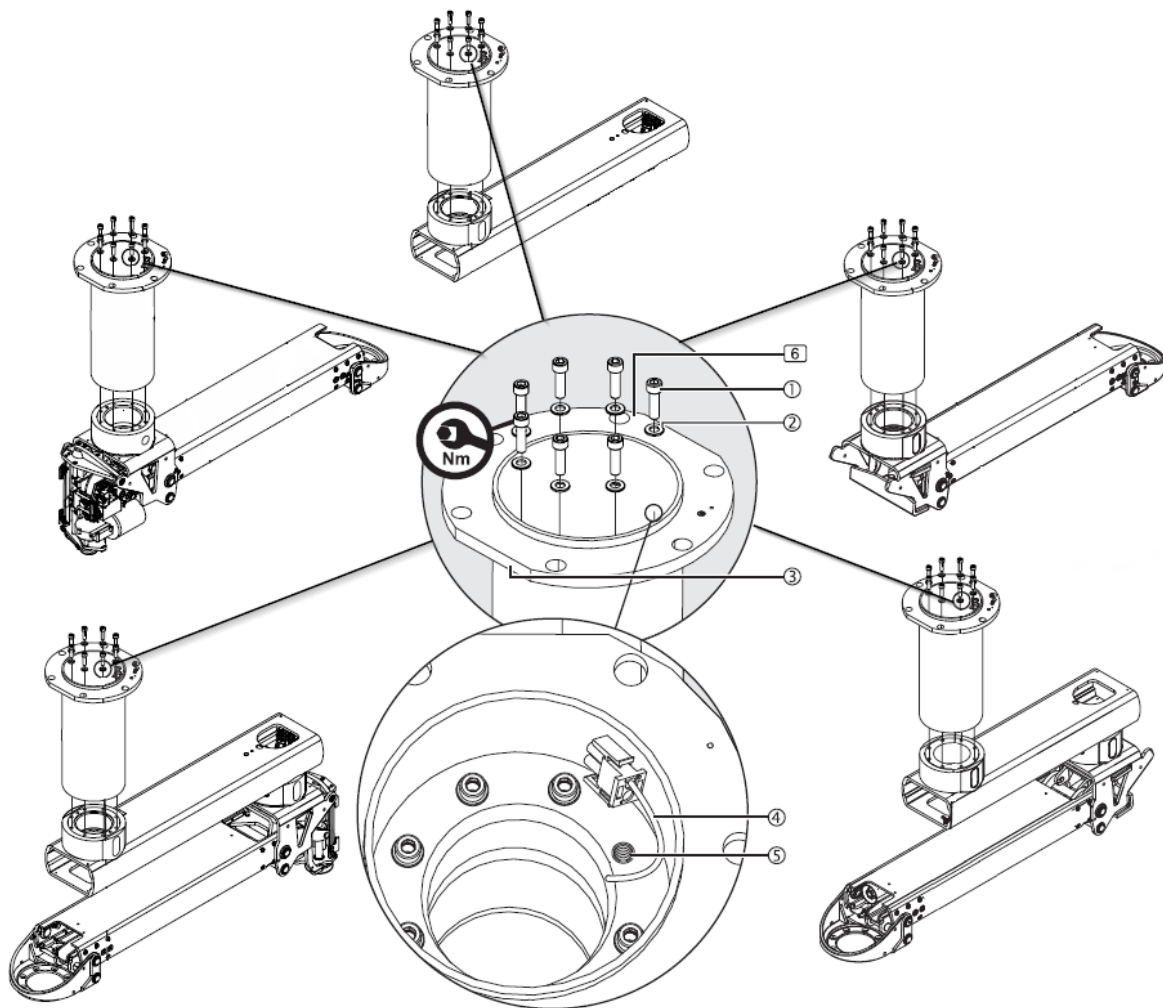

Fig. 26 Mounting the roof tube

- Place the roof tube (6) over the extension arms (4), (5) and position it so that the chamfered surface ③ is almost at right angles to the extension arms (4), (5), as shown in the figure.
- Assign the fastening screws to the individual ceiling tube type (6) according to the chosen configuration:

Anchorage for individual arm systems: 8 socket head cap screws M10 x 25 mm ① - 8.8 - DIN EN ISO 4762 and 8 lock washers S10 ②.

Anchoring on extension arm: 8 socket head cap screws M10 x 25 mm ① - 8.8 - DIN EN ISO 4762 and 8 lock washers S10 ②.

Anchoring on extension arm XL (higher load capacity): 10 hexagon socket head cap screws M10 x 30 mm ① - 8.8 - DIN EN ISO 4762 and 10 lock washers S10 ②.

- Mount the selected screws ① with the corresponding lock washers ②.

- In the position of the pre-assembled cable ④, leave the threaded hole ⑤ free.
- Screw the roof tube (6) to the extension arms (4), (5) with 7 / 9 screws of the selected model and the corresponding lock washers S10 ②.
- Use an extension tool to tighten the 7 / 9 M10 socket head cap screws ① - DIN EN ISO 4762.



The 7 M10 socket head cap screws ① - DIN EN ISO 4762 must be fitted with 7 lock washers ② and tightened to 40 Nm.

- Mount the strain relief mechanism on the roof tube (6).



See section 6.6.3 of this manual.

## 6.6.3. Mounting the tension release mechanism on the ceiling tube

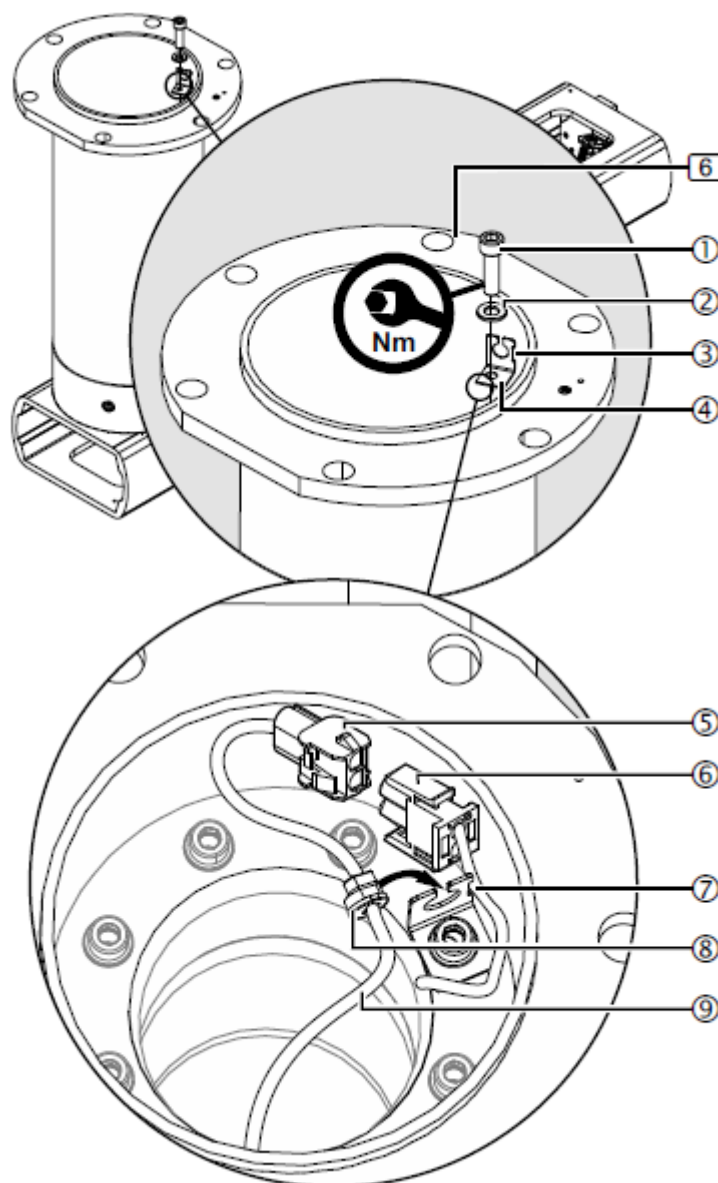

Fig. 27 Mounting the strain relief mechanism

Figure 24 shows the roof tube 6 with 8 hexagon socket head cap screws M10 x 25 mm ① - 8.8 - DIN EN ISO 4762 as an example.

Figure 27 shows a simplified representation with only the drive arm 4 and the extension arm with drive arm 5 without pre-assembled cables.

- Insert an M10 x 25 mm socket head cap screw ① or an M10 x 30 mm socket head cap screw ① and an S10 lock washer ② into the cable gland bracket ④.
- Position the grommet bracket ④ on the roof tube 6 in such a way that the cut-out ③ of the grommet bracket ④ points towards the wall of the roof tube.

- Place the pre-assembled cable ⑦ in the cut-out ③ of the cable gland holder ④.
- Screw the cable gland bracket ④ to the motor arm (4), extension arm with motor arm (5) or XL extension arm with motor arm (5) using the socket head cap screw ① and lock washer ②.
- Make sure that the cable is not ⑦ tight.
- Establish the plug connection ⑤/⑥ with the control cable included in the packaging ⑨ and then push the strain relief mechanism ⑧ into the strain relief bracket ④.
- Check that the strain relief mechanism ⑧ is correctly fitted:
- The control cable ⑨ must be securely unloaded into the strain relief mechanism ④.
- Pass the control cable ⑨ through the roof tube (6) and the motor arm (4) or the extension arm with the motor arm (5) or the XL extension arm with the motor arm (5) to the distributor plate.



The M10 socket head cap screw ① - DIN EN ISO 4762 must be fitted with the lock washer ② and tightened to 40 Nm.

#### 6.6.4. Mounting of the roof tube earthing cable

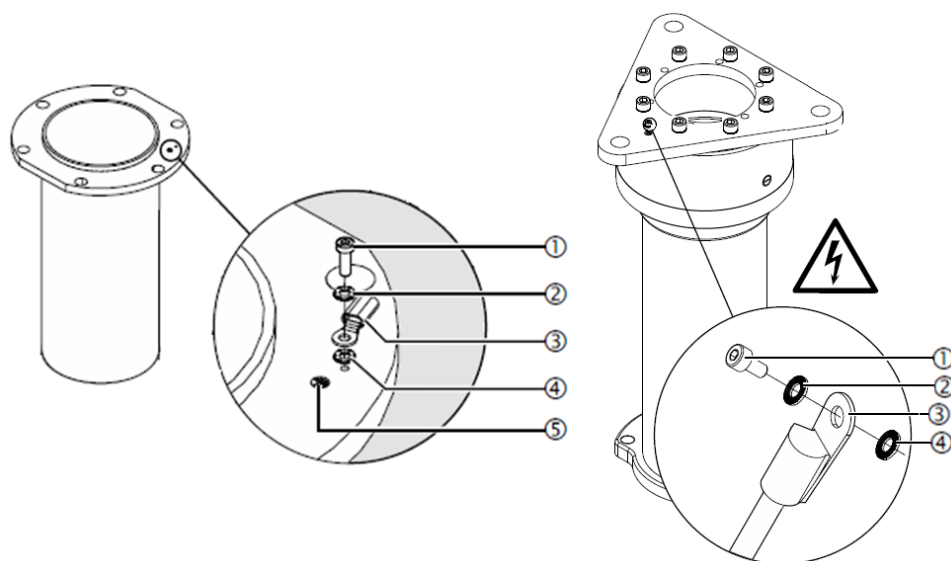

Fig. 28 Assembly of the earthing cable in the drop tube for arms and COLUMN ROTATION

The system is delivered with pre-assembled earthing cable!

- Mount 1 S4 lock washer ②/④ above and below the round terminal ③ of the 4 mm<sup>2</sup> earthing cable (approx. 1 m long) included in the packaging.

- Using 1 socket head cap screw M4 x 12 mm - DIN 912 ①, screw the cable lug ③ and the lock washers S4 ②/④ to the earthing point ⑤.
- Tighten the M4 x 12 mm socket head cap screw ①.

#### 6.6.5. Mounting of the arm on the threaded bolts of the interface plate

In this section we already have the system arm(s) attached to the ceiling tube (6) as shown in figure 29 for the single arm COLUMN AIR (picture top right in figure 29) and the double arm COLUMN AIR (picture top left in figure 29). On the single-arm unit, it has been attached to an extension ceiling tube so that the two suspended systems do not collide when rotating in a tandem assembly. The two pictures below correspond to COLUMN MOTOR.

For all other variants the assembly is identical.

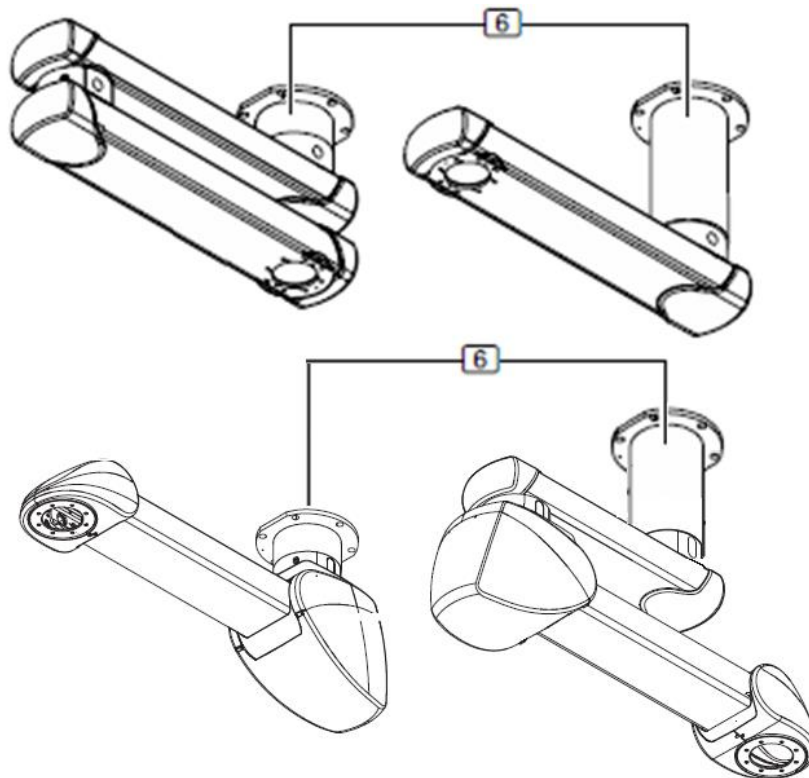

Fig. 29 Double-arm COLUMN AIR and single-arm COLUMN AIR

Figure 30 shows a simplified representation of the roof tube flange ⑥ for mounting on the threaded bolts. Other components such as extension arm, cables, etc. are not shown.



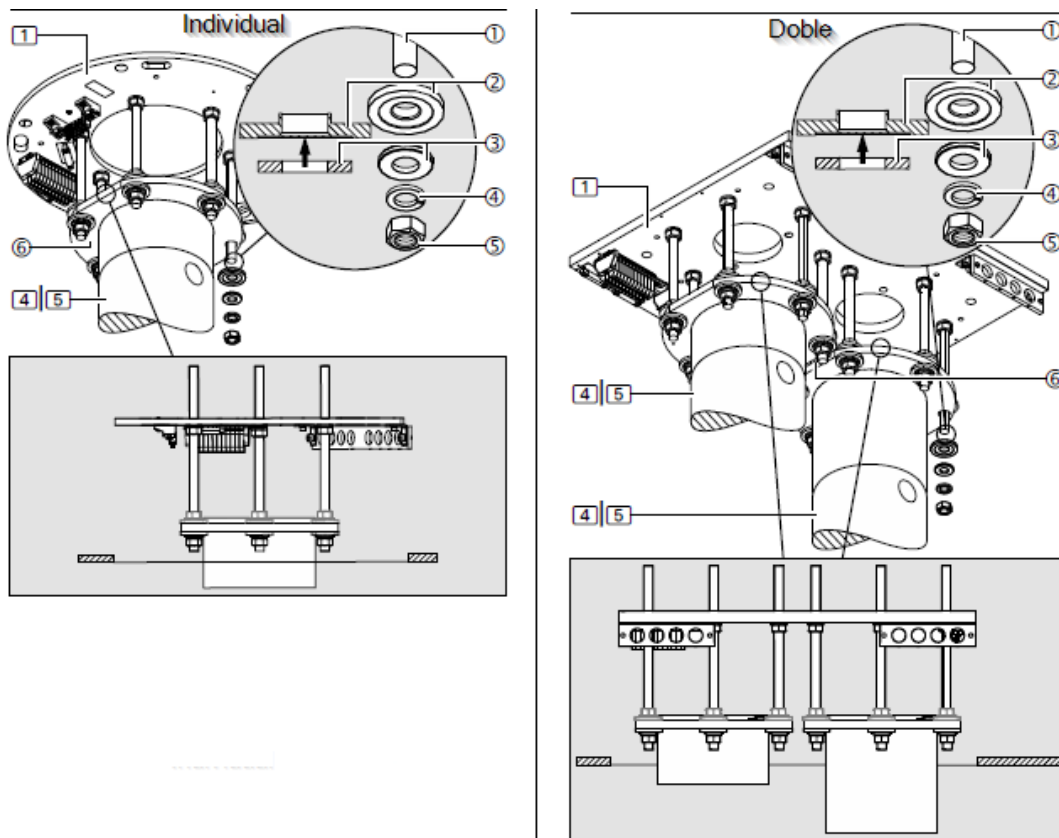

Fig. 30 Assembly of the roof tube flange on the threaded bolts



Make sure that no one is under the hanging system.

Risk of falling parts.

- Securely fasten the roof tube flange (6) or, using a suitable lifting device, place it under the M16 threaded bolts (1) of the interface plate (1).

NOTA

When mounting double systems, it should be noted that the flanges of the roof pipes (6) have a chamfered surface to ensure that they can be mounted at the same height, mount them so that the chamfered surfaces are aligned with each other, as shown in figure 29.

- Insert the roof tube flange (6) into the 6 M16 threaded bolts (1) of the interface plate (1).
- Remove the previously applied adhesive or elastic tape from the threaded bolts (1).
- For each M16 threaded bolt (1), fit 1 plastic insulating disc (2) (as shown in Figure 27) so that the flat washer with an outer diameter of 34 mm (3) (see arrow in the detailed illustration in Figure 30) is seated on the plastic insulating disc (2).
- For each M16 threaded bolt (1), fit 1 flat washer with an external diameter of 34 mm (3), 1 spring disc (4) and 1 M16 hexagon nut (5).

## 6.6.6. Alignment of the arms with the Interface plate

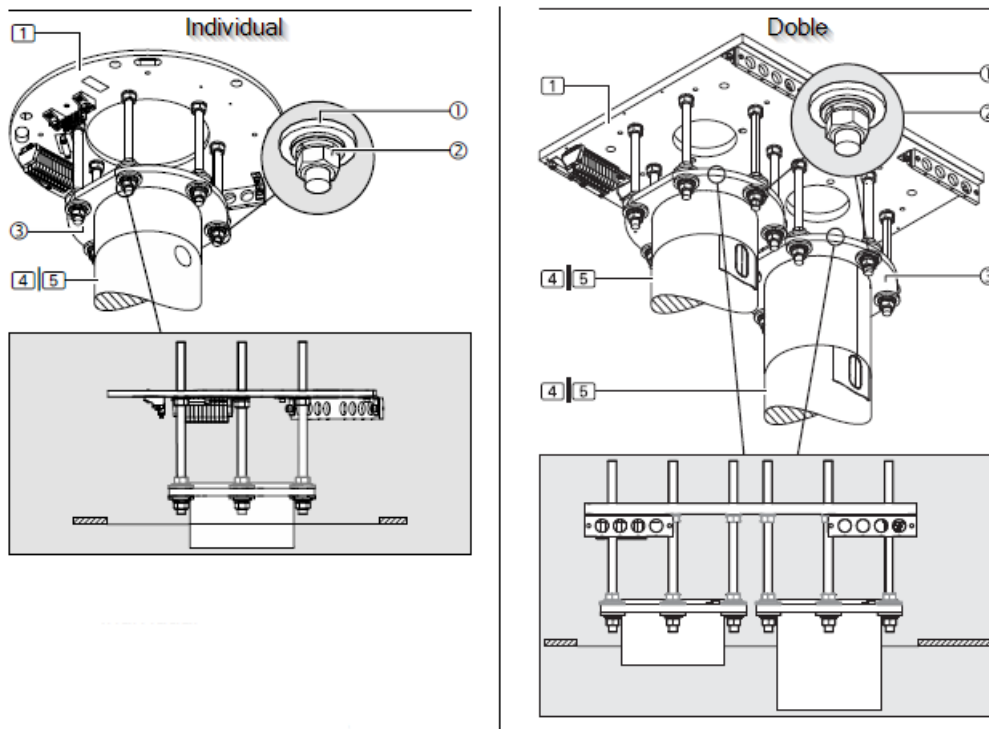

Fig. 31 Alignment of the arms with the Interface plate

- Choose 1 of the 6 M16 hex nuts (2) as a reference point.
- Screw the 6 M16 hex nuts (2) (2) under the flange (3) crosswise onto the flange (3) and tighten to 100 Nm.



Tighten the M16 hex nuts (2) on the flange to a torque of 100 Nm.

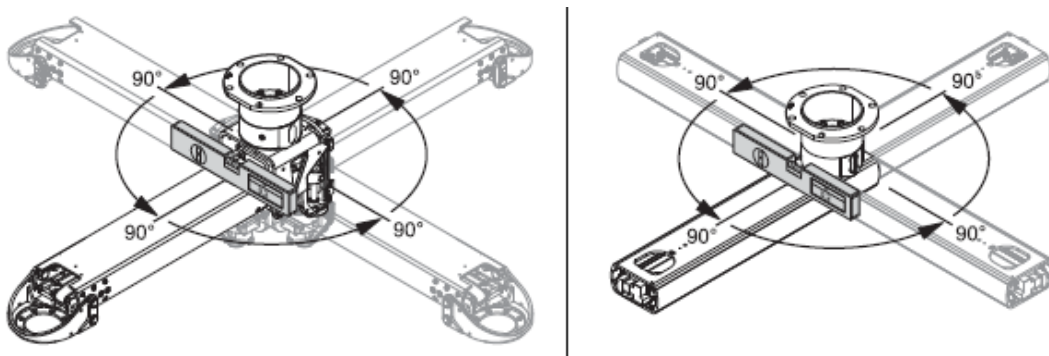

Fig. 32 Checking the horizontal alignment of the outriggers

NOTA

For double arm variants, remove the transport lock (belt) and remove the pre-assembled swivel stop if necessary. Then rotate the lower arm relative to the upper arm.

- Check the horizontal alignment of the extension arms. Place the digital spirit level at right angles to the direction of the arm (near the flange ③). Rotate the arm 90 degrees in various directions and check the horizontal alignment. See Fig. 32.

NOTA

In case of deviations of more than  $\pm 0.2$  degrees, the arms must be realigned. To do this, repeat the installation steps described above.

- Check that all M16 hex nuts ② ② are correctly positioned and tightened once the arms are properly aligned.

### 6.6.7. Assembly of the drop tube on the arms

Optionally, the service head can be ordered already assembled to the drop tube. In this case, the various electrical and gas hoses are routed through the drop tube. Before mounting the drop tube on the suspension system, all electrical and gas hoses must be routed through the suspension system.



See section 6.8 of this manual

For non-powered arms. The figure shows an enlarged section view of the extension arm without its upper part.

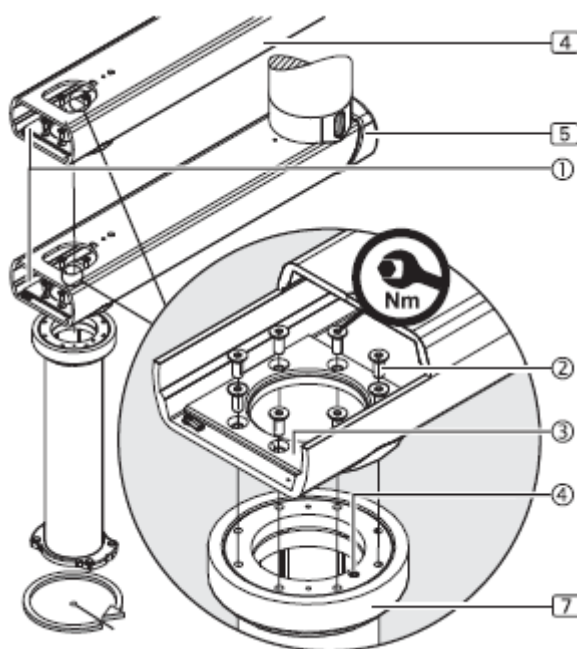

Fig. 33 Assembly of drop tube on NON-motorised arms

- Insert the fixing plate 8 x M10 ③ from the front side ① into the extension arm (4), (5) and fit it.
- Position the drop tube under the extension arm (4) / (5) so that the end stop ④ on the drop tube points away from the side of the extension arm and the fixing holes are aligned.

- In order to be able to turn the service head counterclockwise, the drop tube must be mounted with the end stop ④ on the right side, as shown in figure 30. It will be mounted on the left side if the service head is to be able to turn clockwise.
- Fix the drop tube through the 8 x M10 fixing plate ③ and screw it to the extension arm (4), (5) with 8 countersunk Allen screws ②.

COLUMN and COLUMN INVERTED, COLUMN XL (double arm variant): 8 countersunk socket screws M10 x 25 mm ② - 10.9 - DIN EN ISO 10642

COLUMN XL (single arm variant) and COLUMN XXL: 8 countersunk hexagon socket screws M10 x 30 mm ② - 10.9 - DIN EN ISO 10642



The M10 countersunk screws ② - DIN EN ISO 10642 must be tightened to 40 Nm.

For motorised or spring-loaded arms. Figure 31 shows an enlarged section view of the motorised arm (on the right in Fig. 34) and the spring arm (on the left in Fig. 34) without its upper part.

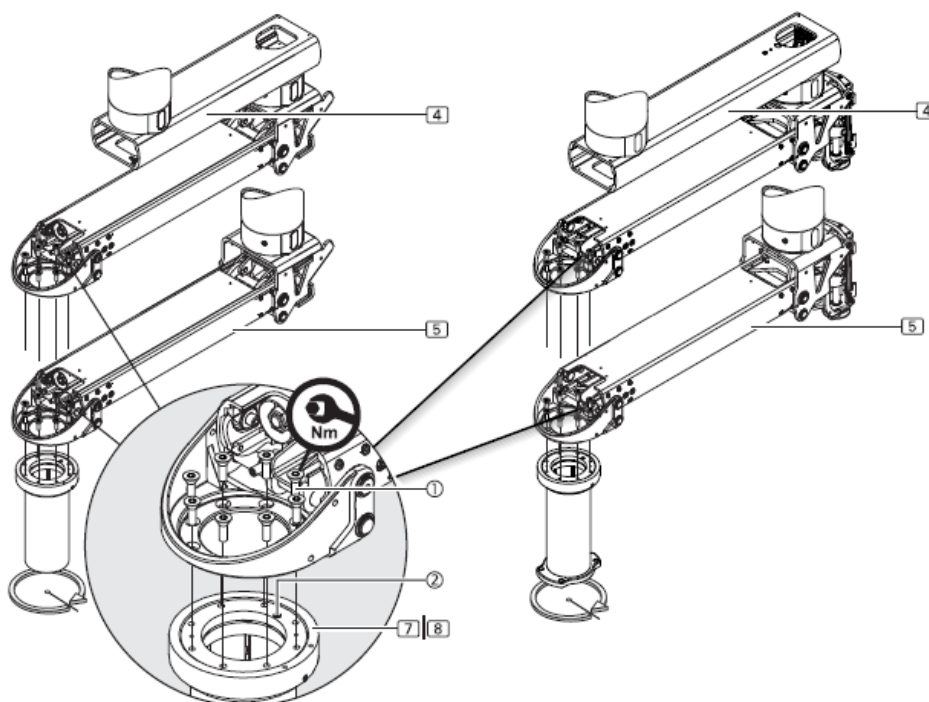

Fig. 34 Assembly of drop tube on motorised and spring-loaded arms

- Position the drop tube under the arm (4) / (5) so that the end stop ④ on the drop tube points away from the side of the extension arm and the fixing holes are aligned.
- In order to be able to rotate the service head counterclockwise, the drop tube must be mounted with the end stop ② on the right-hand side, as shown in figure 31. It shall be mounted on the left side if the service head is to be able to rotate clockwise.
- Fix the drop tube through the 8 x M10 fixing plate ③ and screw it to the extension arm (4) / (5) with 8 countersunk Allen screws ①.

MOTOR COLUMN: 8 countersunk socket head cap screws M10 x 18 mm ① - 10,9 - DIN EN ISO 10642

COLUMN SPING: 8 countersunk socket head cap screws M10 x 25 mm ① - 10,9 - DIN EN ISO 10642



The M10 countersunk screws ① - DIN EN ISO 10642 must be tightened to 40 Nm.

### 6.6.8. Installation of the arm lighting (retrofitting only)

When the system is delivered from the factory, the following options are fitted.

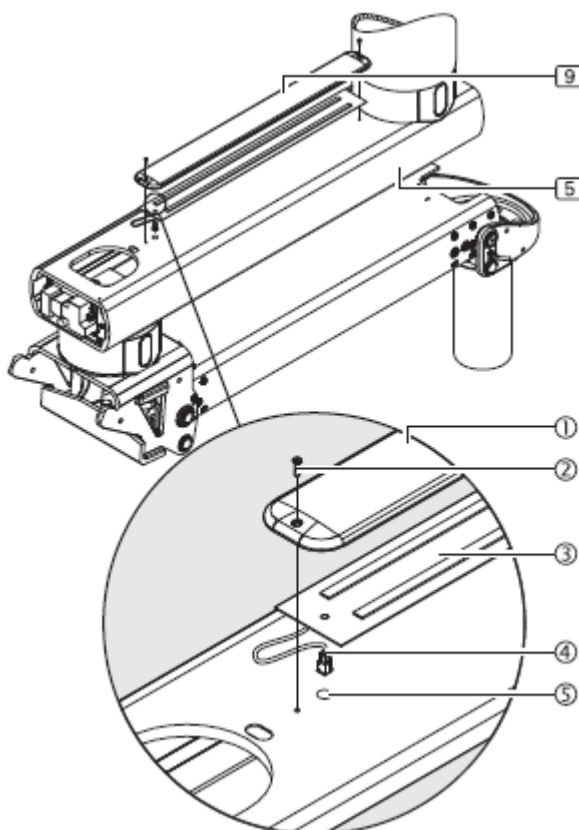

Fig. 35 Mounting of indirect lighting module

The indirect lighting (9) of the extension arm (5) (lengths from 800 mm and 1000 mm for the XL model) is mounted on the upper part of the arm. Figure 35 shows a simplified representation with only the extension arm and spring arm (5) without pre-assembled cables.

- Remove the 3 sealing plugs (not illustrated) from the top of the extension arm and dispose of them in accordance with legal regulations.
- Pass the connection cable ④ of the basic holder with LED ③ through the mounting opening ⑤ to the extension arm without bending it.
- Place the cover ① on the basic holder with LED ③ and screw it on with 2 countersunk head screws M4 x 16 mm ② - DIN EN ISO 10642.

- Check that the extension arm lighting (9) is properly positioned and level with the extension arm, that the connection cable (4) is on the extension arm and that the screws are tightened securely.

#### 6.6.9. Fitting of brake indicators (retrofitting only)

For the COLUMN - INVERTED version, the extension arm lighting is mounted on the front of the upper arm (not shown).

When the system is delivered from the factory, the following options are fitted:

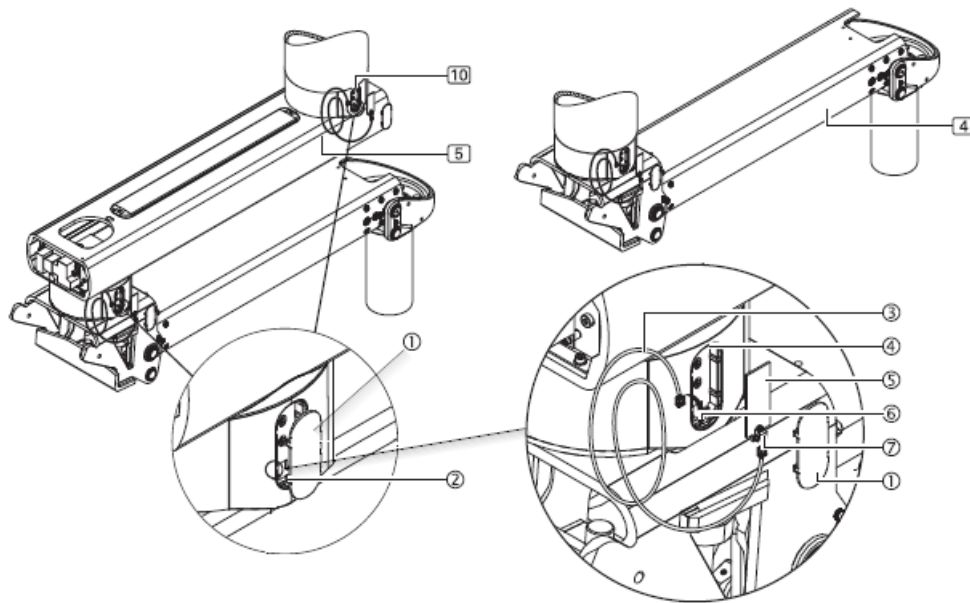

Fig. 36 Fitting the brake indicators

The figure shows an extension arm (5) with a spring arm (4). The installation procedure for the XL extension arm version with spring arm (4) is identical. The brake indicators (10) are mounted on the pivot or brake points of the arms.

Thus a double arm system incorporates 4 brake indicators (10), while the single arm version incorporates only 2.

1. Gently unhook the 2 / 4 plastic covers (1) on the 4 latches (2), remove them and store them in a safe place.
2. Plug 1 connector of the power cable (3) into the connector plug (7) of the lighting board (5).

Colour code of lighting boards (5): Upper bearing = green and Middle bearing = blue

3. Pass the power cord ③ through the hole ⑥ (see arrow) into the extension arm. Make sure that the plugs and the power cord ③ are not damaged and that the power cord ③ is fully seated in the extension arm.
4. Hook the illumination plate ⑤ from the bottom into the mounting opening ④ and carefully push it in until it audibly clicks into place, DO NOT push it in with force.
5. Check that the illumination plate ⑤ is correctly positioned, it must be seated in the mounting opening ④ without snapping into place.

## NOTA

The colour code of the plastic covers ① shall be green for single arm systems and for double arm systems it shall be green on the top and blue on the bottom.

6. Gently push the 2 / 4 plastic covers ① into the mounting opening ④ until the 4 latches ② audibly click into place.
7. Check that the plastic covers ① are securely in place and are seated in the mounting opening ④ without snapping into place.
8. Place the service head (or CEMOR bracket if applicable) under the pendant system as described in the Service Head Installation Instructions.

### 6.7. Service head assembly

Only for orders where the service head does not come with the drop tube pre-assembled.

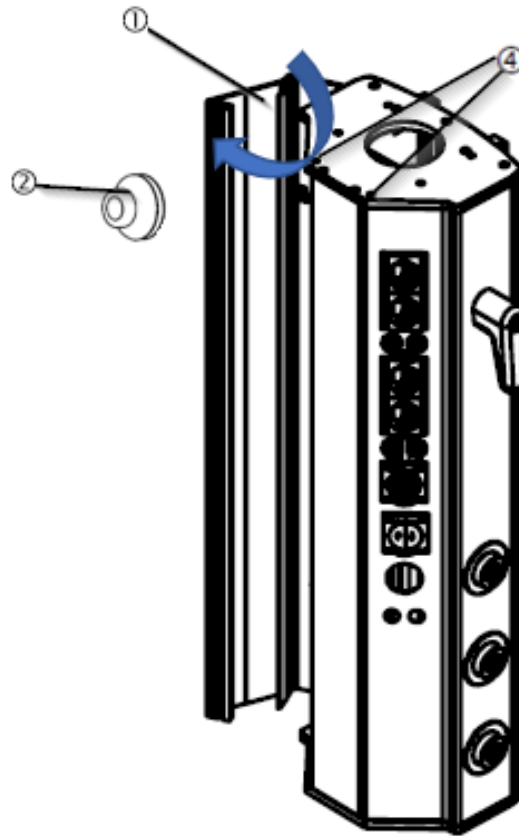

Fig. 37 Opening the service head covers.

Once the boom system has been attached to the ceiling of the system, the service head can be mounted. All the hoses for the electrical supply, for the supply and control of the brakes or motors (depending on the configuration of the suspended systems) and all the hoses for the supply of the different medical gas and/or vacuum systems are pre-assembled on the service head. It also includes a corrugated tube with a guide for the installation of the communications cables provided.

- Present the service head in front of the drop tube of the boom system(s) with the aid of the working platform.
- Route all electrical/voice and data cables and gas hoses pre-assembled in the service head through the arm/s system.



See section 6.8 of this manual.



- Open one of the side covers of the service head ① by removing the M4x16 socket head cap screws ④ at the top and bottom. The side cover can now be opened as shown in figure 38, revealing the inside of the service head.



Fold down the cover of the enclosure with the help of a plastic suction cup ②.

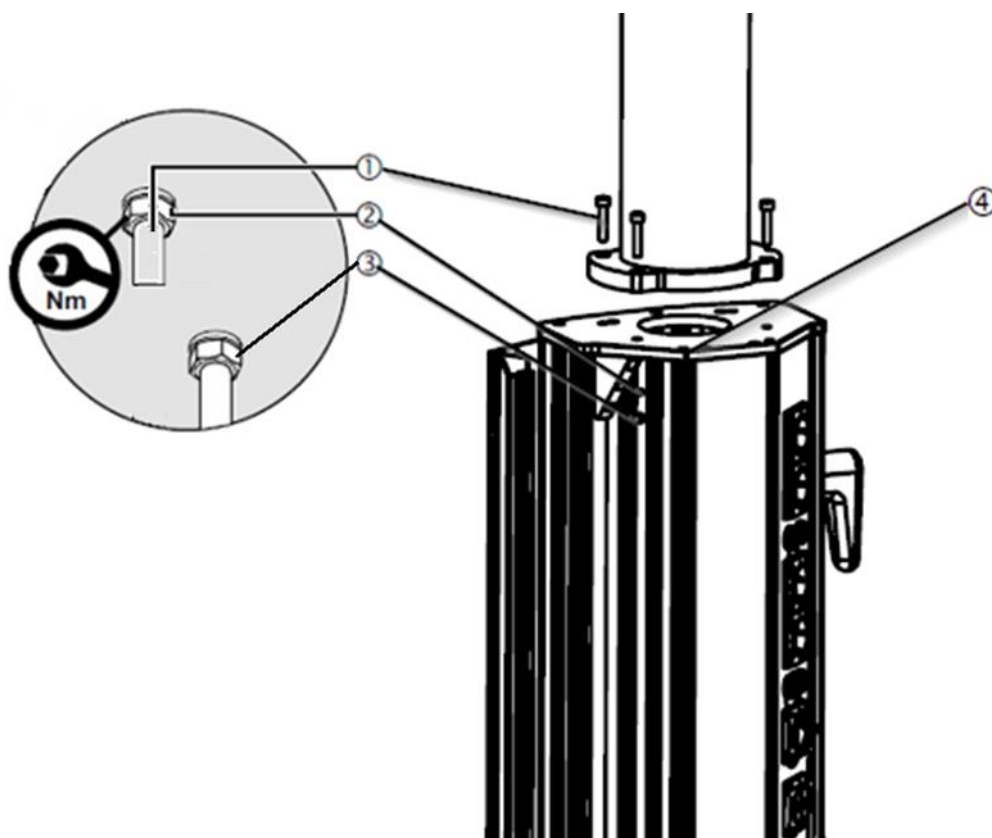

Fig. 38 Mounting the service head on the drop tube.

- Fit the 4 M8 socket head cap screws ① into the 4 recesses provided on the top of the service head.
- For each M8 socket head cap screw ①, place 1 S10 lock washer ② (as illustrated in Figure 38) so that the flat washer is seated between the upper seal of the service head (on the inside) and the corresponding hexagon nut ③.



The M8 socket head cap screws ① - DIN EN ISO 10642 must be tightened to 40 Nm.

- Once the service head has been secured, replace the M4x16 hexagon socket head cap screws ④ in their original position and tighten them.

## 6.8. Cable / hose routing



Before any installation and adjustment work, the pendant system must be disconnected from the mains.

Damaged power cables can carry 230 V electrical voltage that energises the pendant system, and supply gases can escape from damaged supply hoses:

- Check all cables and hoses for damage. Be sure to insert them carefully without the cables/hoses crossing each other, without loops and without kinks.
- Cables and pipes must be positioned in the suspension system in such a way that they are not exposed to tensile stresses.
- Cables and hoses must be routed straight up out of the flange to prevent damage (e.g. chafing of the sheathing) and to allow free rotation.
- Protruding cables and hoses must not be routed in the service head or on the flanges, but must be routed in the interface plate and secured against falling out with cable retainers.
- Electrical cables should be routed according to regional standards (in a spiral coiled tube if necessary).

**NOTA**

For systems with air brakes, check air supply lines and brake valves for contamination and clean if necessary.

- Cut the brake hoses,  $\varnothing$  4 mm, flat-parallel.
- Brake lines and air supply lines must not be bent.
- Replace damaged or bent brake lines.
- The supply pressure of the air supply ducts at the installation site must be in the range of 4 to 6 bar. The optimum operating pressure is 5 bar.

Power cables, pneumatic lines, earthing and control cables as well as gas hoses are pre-installed in the service head and must be routed through the pendant system. Order-specific cables, including telephone and nurse call cables, must be routed separately through the pendant system.

6.8.1. Connection of pneumatic brakes

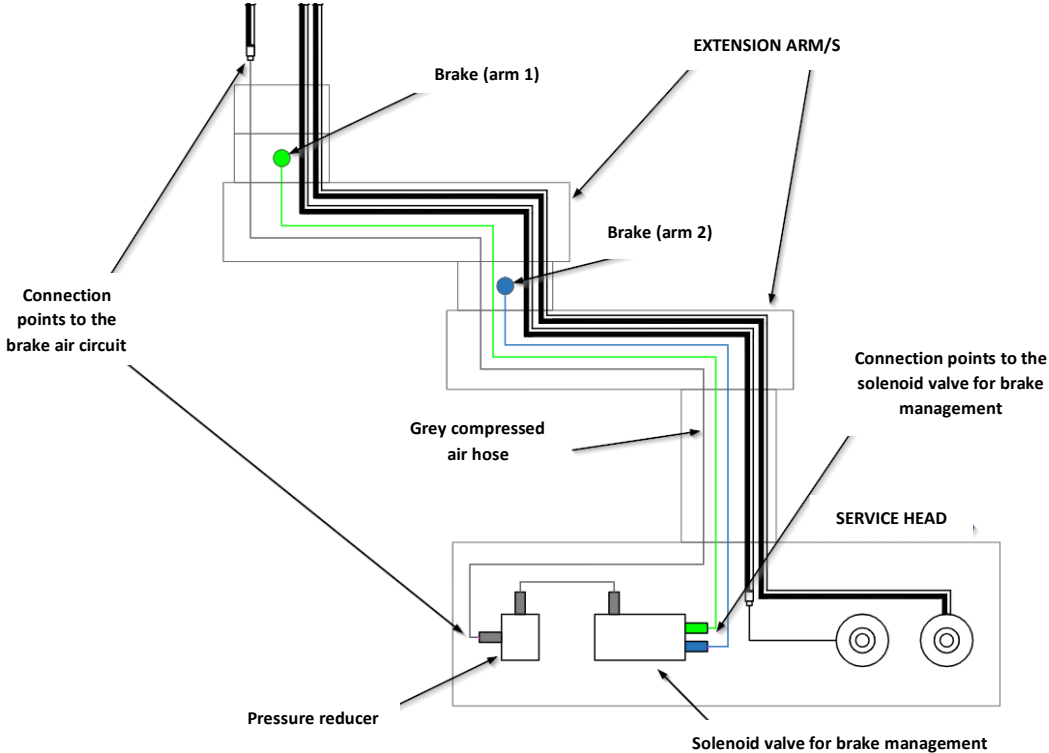

Fig. 39 Routing of brake air hoses. Colour coding

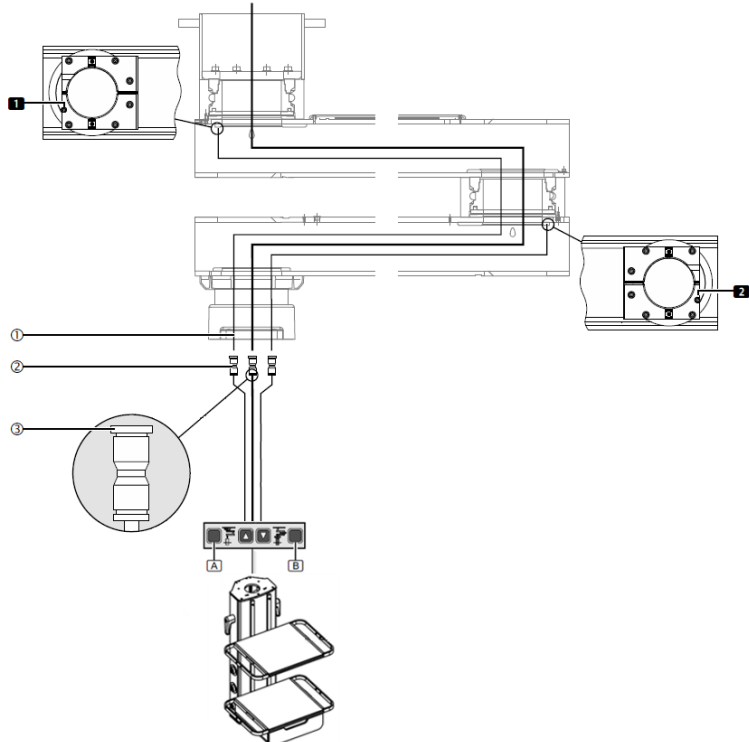

Fig. 40 Routing the air hoses for the brakes. Connection.

The pneumatic brake hoses ① are pre-mounted on the suspension system and connected to the brake connection points (1) and (2). If necessary, the brake hoses ① are fitted in the form of a spiral tube.

The pneumatic supply line must be depressurised:

- To install the brake hoses, push them into the brake connection point. If the brake pipe is correctly positioned, it can no longer be removed from the brake connection point.
- To disengage the brake hoses at the connector ② press the release mechanism ③ and then remove the brake hoses.
- Plug the air supply hose (BLACK mark) into the connector ② (BLACK mark).
- Plug the brake hose (GREEN marking) into connector ② (GREEN marking).
- Plug the brake hose (BLUE marking) into connector ② (BLUE marking).
- Connect the air supply hose and the 2 brake hoses ① to the plug connector as described in the Service Head Installation Instructions.
- The brake tubes ① may be too long depending on the installation position of the rack. If this is the case, cut the brake hoses ① to length.

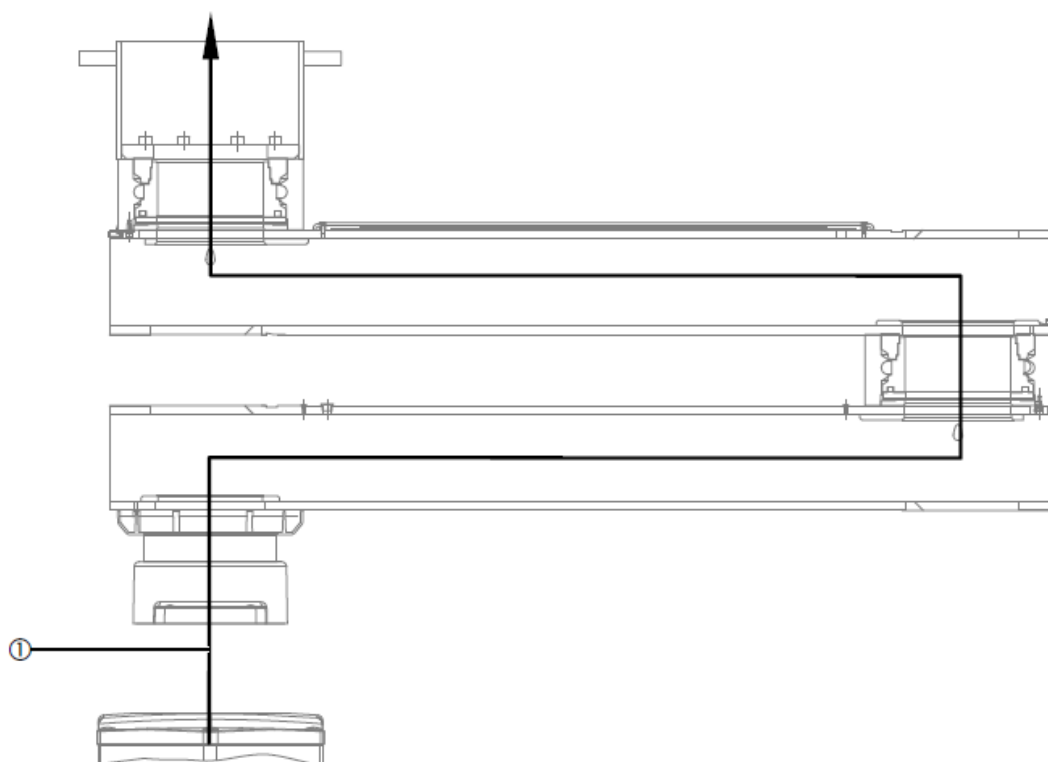

Fig. 41 Routing of the air brake power cable

- Route the power cable ① (in a spiral coiled tube if necessary) through the pendant system and into the interface plate as shown in Figure 36.

- Perform a functional test as soon as the service head is fully installed:
- Press the green brake button A. The brake on the upper extension arm must be released.
- Press the blue brake button B. The brake on the lower extension arm should release.

### 6.8.2. Connection of supply and management circuits for electromagnetic or motor brakes

The supply cables and hoses are pre-assembled by Tedisel. All connections for the management of the electromagnetic brakes and/or motors are pre-assembled on the service head.

NOTA

For the COLUMN INVERTED version, the cables are routed upwards through the front upper extension arm (not illustrated).

The following figure illustrates the connection of the electromagnetic brakes in a double arm system. For the single arm case the connection between the service head and the drop tube output cables are connected in the same way, in this case there will only be one supply line to the interface board as there is only one brake.

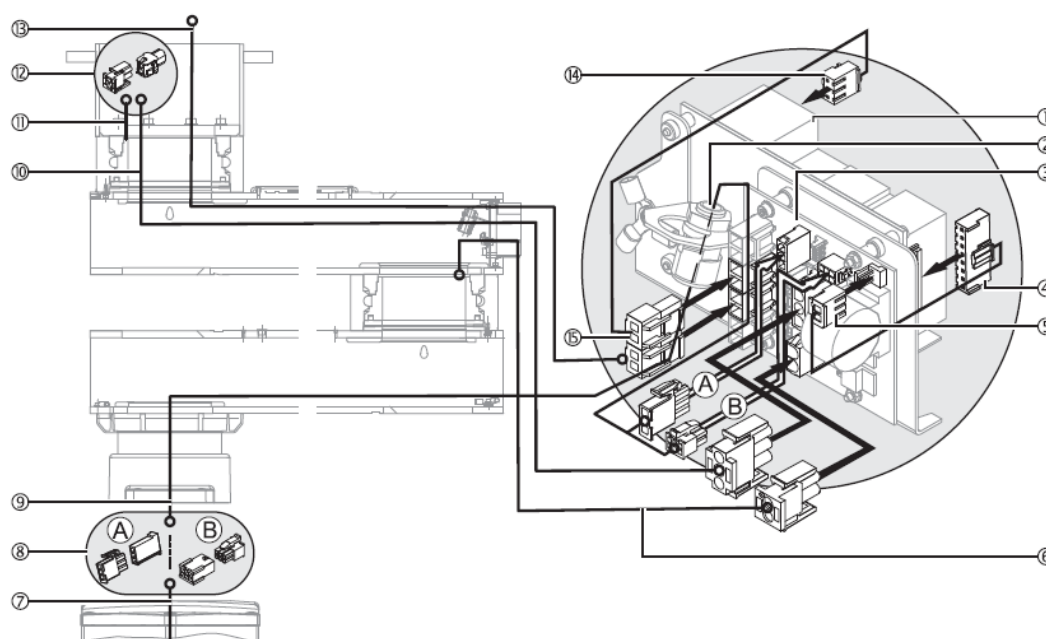

Fig. 42 Connection of grounding cables

- Check that the connection cables are fitted with the plugs ④/⑤ and ⑭/⑮ between the power supply unit ① and the distributor board ③. If missing, fit the connection cables included in the packaging with the plugs ④/⑤ and ⑭/⑮ as shown in the figure.
- Connect the upper brake by establishing the mounting connection ⑫ between the cable ⑪ and the extension cable ⑩ via the release mechanism as described in point 6.6.3 of this manual.

- Plug the connector of the extension cable ⑩ into the corresponding distribution board socket ③ as illustrated in the figure.
- Connect the lower brake by plugging the cable connector ⑥ into the socket on the corresponding distribution board ③ as shown in the figure.
- Establish the mounting connection ⑧ of the control cable ⑦ of the service head with the control cable ⑨ by retrieving the control cable ⑨ that is coiled at the highest point of the drop tube.
- Plug the power cable ⑬ included in the scope of delivery into the socket on the corresponding distribution board ③ and pass it through the extension arm to the interface board as shown in the figure.
- If required, Tedisel can provide a circuit diagram/wiring diagram.

N° in Fig	From	To	Disengagement	Length [mm]	Observation
⑥	Bearing unit	Distributor board	-	100	Integrated in the bearing unit
⑦	Faceplate	Drop tube	Service head socket / distributor board		Integrated in service head
⑨	Distributor board	Service head	Cable card / service head	2600	-
⑩	Bearing point 1	Distributor board	Brake cable 1 / Distributor plate	1100 - 1500	Arm length 600/800 - 1000/1200
⑪	Bearing unit	Cable ⑩, distribution	-	100	Integrated in bearing unit
⑬	Network connection	Distributor board	Mains cable / Distribution board	5000	-

Table 1. Cable assignment of the pendant system, double arm variant.

### 6.8.3. Connection of the earthing cables to the support arm

The earthing cables are pre-assembled on the extension arm and must be routed and connected in the direction of the arrow.

- Route and connect the grounding wires in the direction of the arrow shown in the figure and, if necessary, route them towards the interface board.
- Route the mounted grounding wires ① from the flange along the roof tube to the interface plate.
- Route the grounding wires ② out of the service head through the pendant system and into the interface plate.

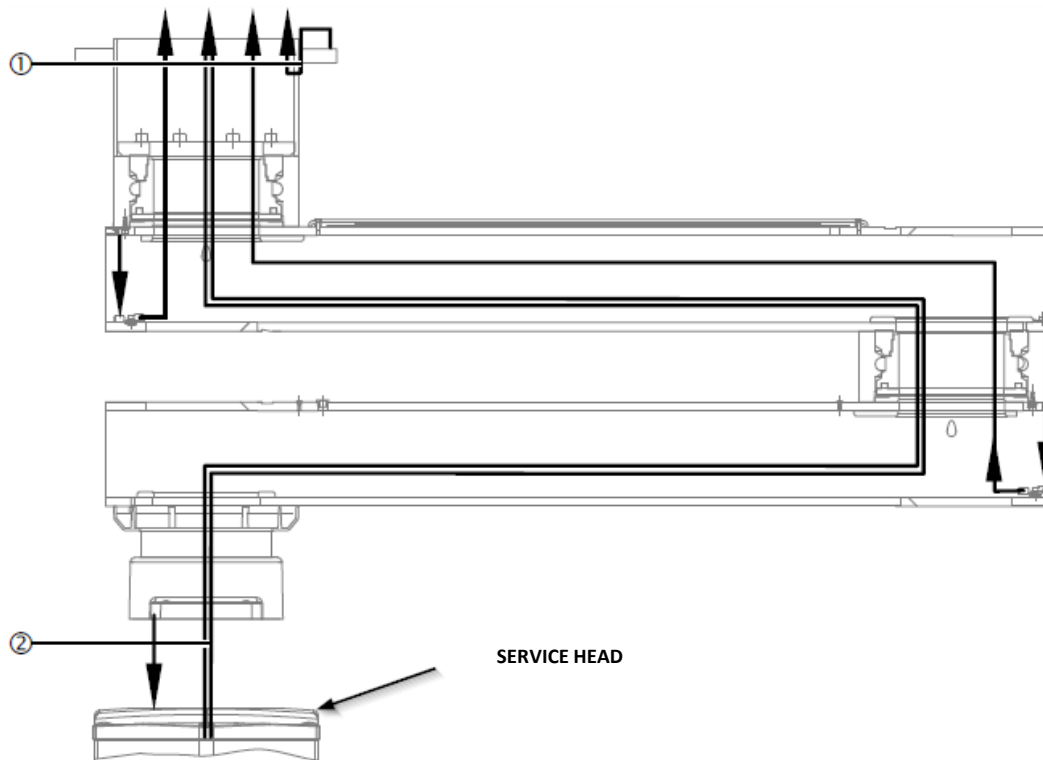

Fig. 43 Connection of earthing cables

#### 6.8.4. Laying of power cables and hoses through the support arm

Power cables and gas hoses are pre-assembled in the Service Head. Order-specific cables, including telephone and nurse call cables, must be routed separately through the pendant system.

- Carefully route the power cables and hoses ① through the pendant system and onto the interface plate:

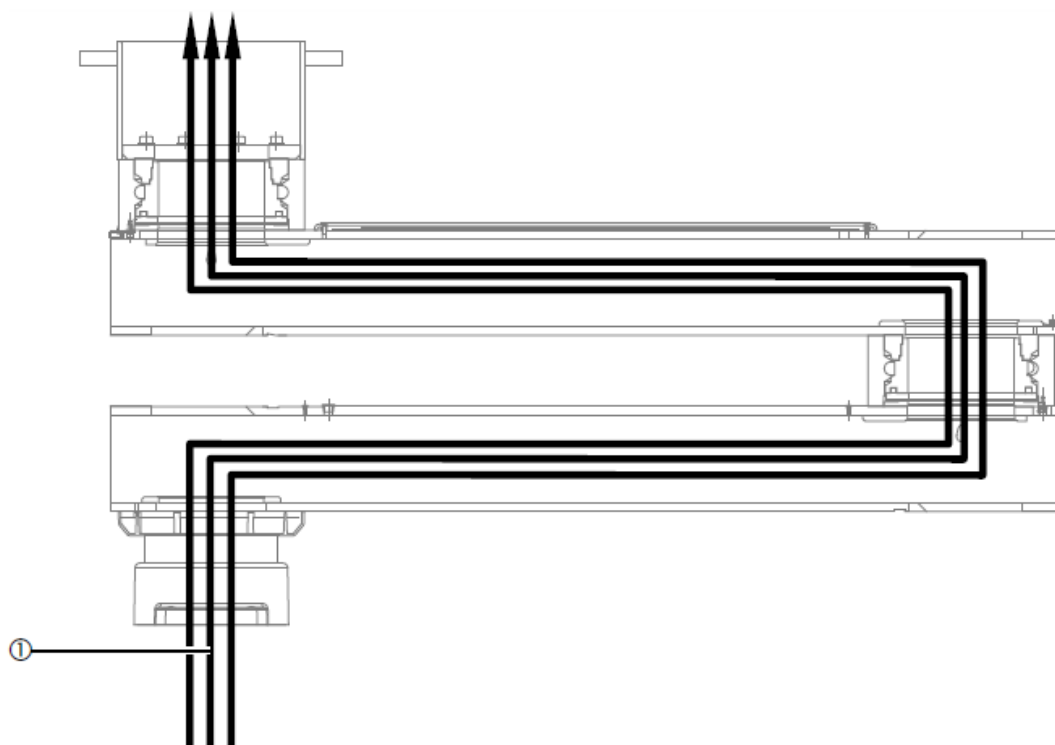

Fig. 44 Laying of the supply cables and hoses through the suspension system

- Then guide the service head without putting any strain on the supply cables and hoses ①.
- Make sure that the cables laid are not damaged or torn out.
- Pass the order-specific cables (nurse call, telephone, etc.) through the pendant system.
- Mount the service head on the pendant system.



See section 6.7 of this manual.

#### 6.8.5. Installation of gas hoses and air exhaust ducts

- Ensure that gas types are correctly assigned

The gas type is indicated by colour on the gas supply hoses. These hoses are fitted with a sealing plug which can only be removed during installation.

- Check hoses and lines for dirt and clean them with oil-free air.
- Ensure that the cables, hoses and conduits are assigned to the correct supply outlet points. See diagram in figure 45.



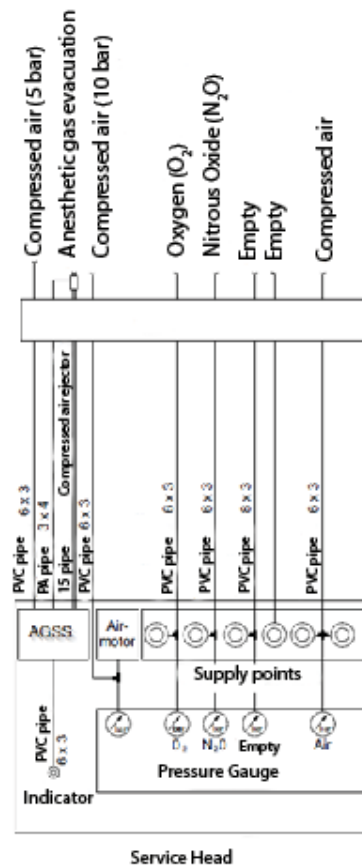

Fig. 45 Example of connection of gas hoses and anaesthesia gas evacuation systems

- Check the gas supply hoses for contamination and clean them with oil-free air.
- Attach a hose clamp to the gas supply hose, remove the sealing plug and push the hose into the correct gas supply outlet.
- Up to 3 gas supply hoses and up to 2 vacuum hoses can be connected to one gas valve using Y-connectors.
- Press on the hose clamp and check that it is securely in place.
- Connect and secure the anaesthetic gas suction hoses and anaesthetic gas evacuation hoses.
- Perform a gas type test by following these 5 points:
  1. gas outlets and marking according to EN ISO 9170-1 or EN ISO 9170-2
  2. Leakage according to EN ISO 11197
  3. Congestion according to EN ISO 7396-1 or EN ISO 7396-2
  4. Solid contamination according to EN ISO 7396-1 or EN ISO 7396-2
  5. Gas type according to EN ISO 7396-1 or EN ISO 7396-2

### 6.8.6. Connection of the different electrical circuits

Figure 46 shows a simplified illustration of the interface board (1) without extension arm and cables, etc. Wiring shall always start with the equipment grounding wires.



Before any installation and adjustment work, the pendant system must be disconnected from the mains.

- Cut all green/yellow earthing wires (2.5 mm<sup>2</sup> and 10 mm<sup>2</sup>) to the correct length.

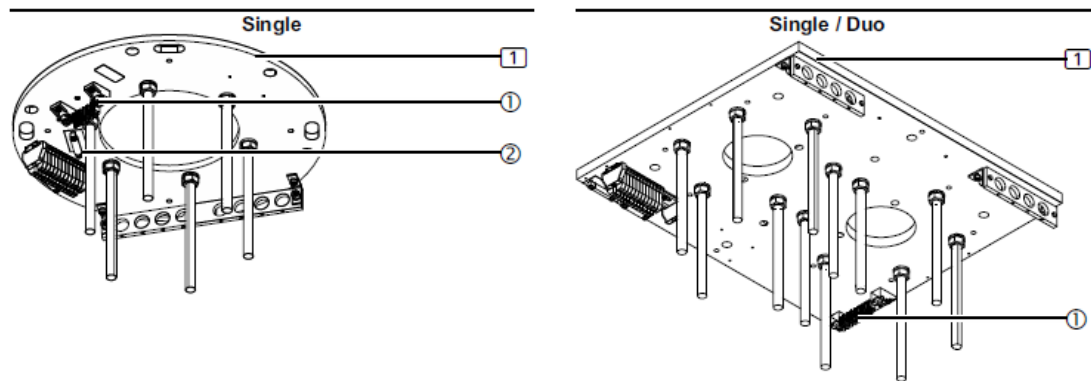

Fig. 46 Connection of the earthing cables on the interface board

- Pass the grounding wires through the strain relief mechanism and connect them to the 4 mm<sup>2</sup> or 10 mm<sup>2</sup> series terminals on the grounding terminal block (1) on interface board 1.
- All earthing cables must be securely installed in the strain relief mechanisms (2).

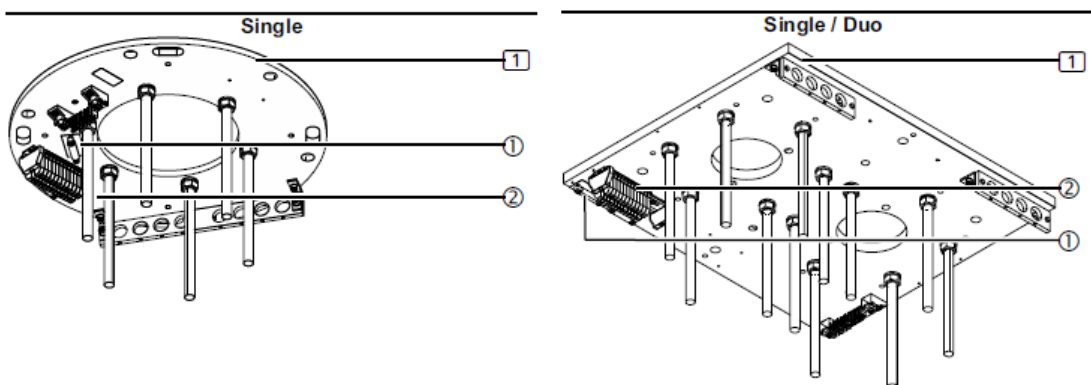

Fig. 47 Connection of the power supply cables on the interface board

Figure 47 shows a simplified illustration of the interface board 1 without extension arm and cables, etc.



Before any installation and adjustment work, the pendant system must be disconnected from the mains.

- Pass all power wires through the strain relief mechanism ① and connect them to the terminal block ② as illustrated in the wiring diagram provided at the installation site.
- All power cables must be securely installed in the strain relief mechanisms ①.
- Carefully check that the power cables are not trapped or bent during the entire rotational movement of the extension arms.

#### 6.8.7. Extension arm lighting connection (optional)

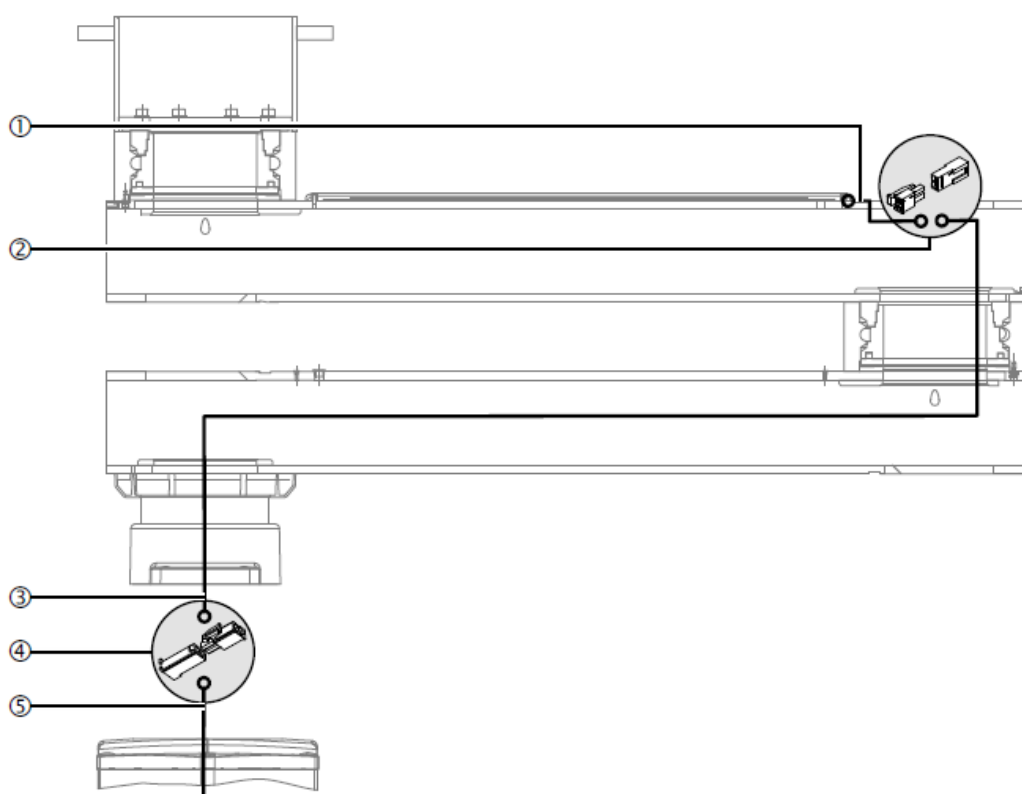

Fig. 48 Connection of optional accessories to the support arm, double arm variant

- Establish the mounting connection ② between the cable ① and the extension arm lighting with the extension cable ③ included in the packaging.

NOTA

Only for modifications to an already installed product, if the product is delivered with the factory option, the mounting connection ② has already been made.

- Route the extension cable ③ through the extension arm and out of the console tube.
- Establish the mounting connection ④ between the extension cable ③ and the control cable ⑤ routed outside the service head.

## 6.9. Fitting of trims

### 6.9.1. Fitting of a single / double trim

The figure shows a simplified illustration of the interface board without cables and without the extension arm.

- Screw the M10 hex nuts ① onto the M10 x 360 mm threaded bolts ②.
- Screw the M10 x 360 mm threaded bolts ② into the interface plate (1) in such a way that the canopy halves mounted below are flush with the suspended ceiling.

If an interface plate (1) is mounted directly to the forging, the threaded bolts M10 x 360 mm ② must be cut to length.

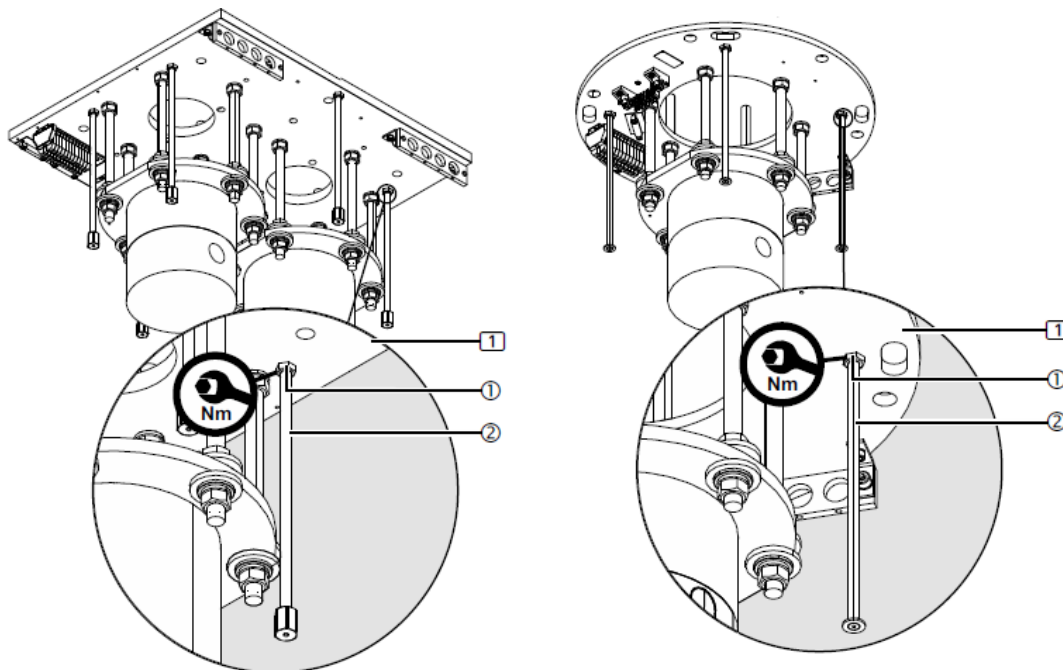

Fig. 49 Preparation of the installation



The 4 M10 hex nuts ① must be tightened to 46Nm.

- The M10 x 360 mm threaded bolts ② must be mounted at the same distance from the interface plate 1.

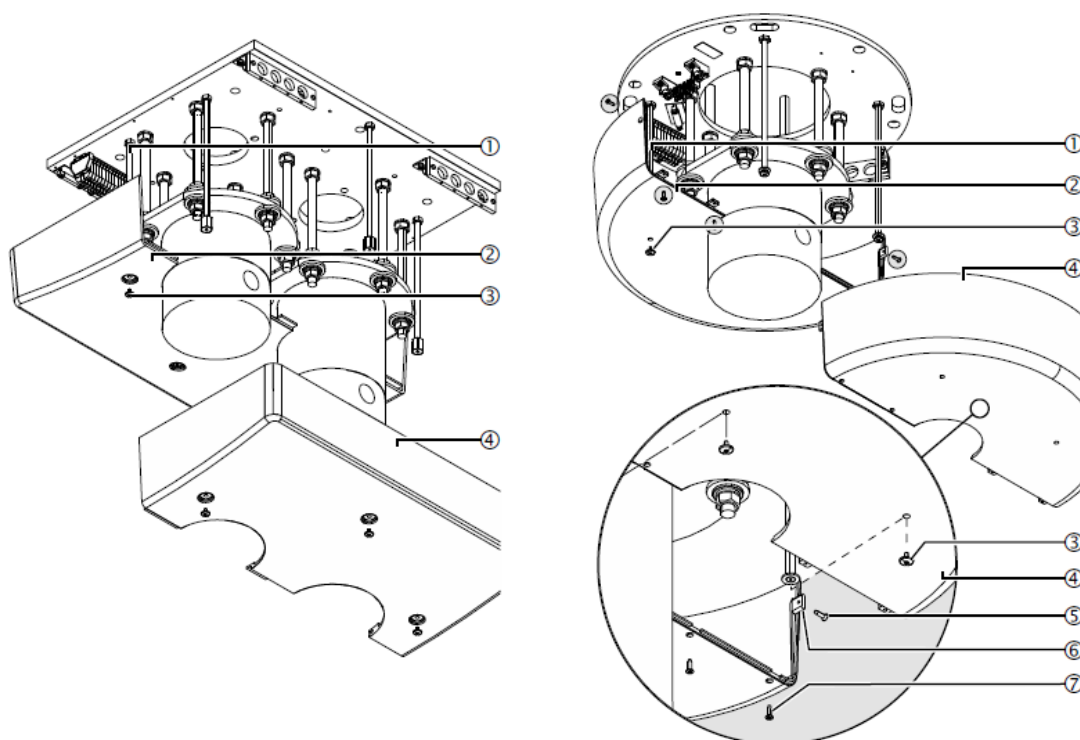

Fig. 50 Assembly of the trim halves

- Place the sectional strip (not shown in the figure) on the first half of the trim (2) as shown in figure 50 (optionally, the canopy can be sealed with silicone).
- Fit the first half of the trim (2) onto the M10 x 360 mm threaded bolts (1) and then screw on and tighten the cover screws (3).
- Check that the trim half (2) is flush with the false ceiling. If necessary, refit the 6 threaded bolts M10 x 360 mm (1).
- Place the section rail (not shown) over the second half of the bonnet (4) and push it onto the first half of the trim (2) so that they fit tightly together.
- Fit the second half of the trim (4) onto the M10 x 360 mm threaded bolts (1) and then screw on and tighten the 3 cover screws (3).

## 6.9.2. Fitting of protective covers. Covers

### 6.9.2.1. Assembly/disassembly of protective caps on an extension arm

The figure shows a device with extension arm and with motor arm (5). The installation procedure for the XL extension arm version (5) with motor arm or spring arm is identical. A simplified representation is shown with only the extension arm without cables. The detailed representation shows a sectional view of the cover (1).

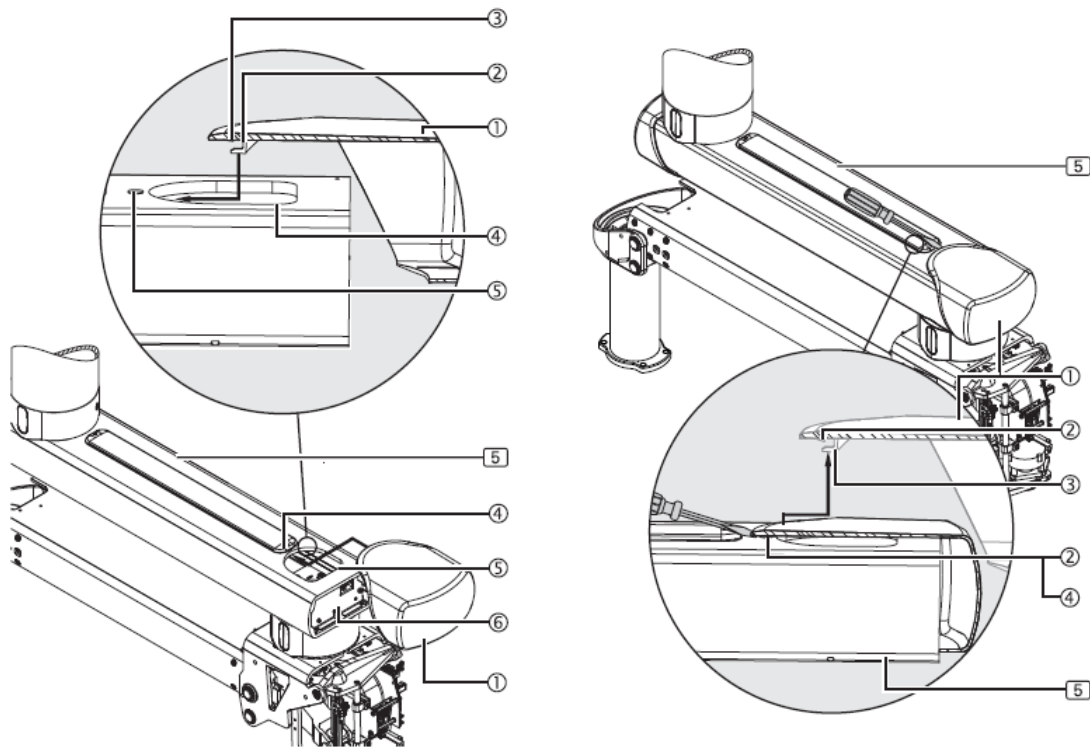

Fig. 51 Assembly (left) / disassembly (right) of protective caps on an extension arm.

- Place the protective cap ① on the end of the extension arm (5) and ensure that the retaining clip ② is seated in the opening ④.
- Push the cover ① onto the extension arm (5) as far as it will go and make sure that the latch ③ fits into the slot ⑤. Make sure that the cables are not damaged.
- If correctly mounted, the cover ① can no longer be removed from the extension arm (5).
- Check that the cover cap ① is absolutely at the same height as the extension arm (5).
- To remove the protective cover ①, insert a small flat screwdriver between the protective cover ① and the extension arm (5) and gently push the latch ② out of the slot ④. Make sure not to damage the paint on the extension arm, the latch ② and the protective cover ①.
- Pull the cover ① backwards until the retaining clip ③ no longer engages and the cover ① can move freely. Do not twist the cover ① and do not remove it with force.
- Remove the protective cap ① upwards and store it in a safe place.

#### 6.9.2.2. Mounting of rear and front covers on a motor or spring arm

The figure shows the motor arm (4). The installation procedure for the extension arm (5) with motor arm (4) or the XL extension arm (5) with motor arm (4) is identical. The figure shows a simplified representation with only the motor arm (4) without cables.

**NOTA** If the front cover is confused with the back cover or vice versa, there is a risk that the covers will be damaged and become unusable.

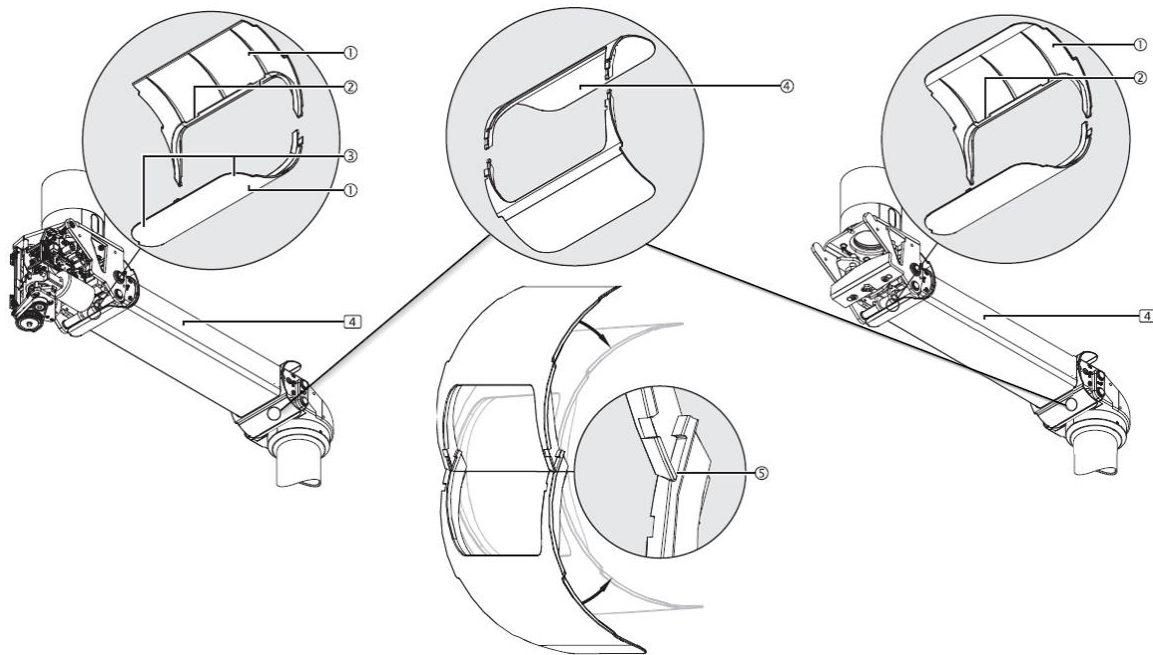

Fig. 52 Mounting of the rear and front protective covers on a spring or motor arm

- For a motorised arm, observe the cover plate positions indicated in the description below.
- Fit the 2 halves of the rear protective cover ① (motor or spring side), see the 2 cut-outs ②, around the motor/spring arm (4).
- For a motorised arm, the upper and lower protection covers do not have the same construction. In addition, the lower protection cover can be easily distinguished due to its rounded corners ③.
- To ensure that the protective cover halves ① fit securely in place, place them inside each other in the correct position ⑤ illustrated in the figure and then glue them in the direction of the arrow. The protective cover halves fit together and are connected.
- Check that all latches of the protective cover halves ① are securely latched together.
- To fit the front covers ④ repeat the procedure (without cutting ②).

#### 6.9.2.3. Mounting of rear side covers on a motor or spring arm

The figure shows the motor arm (4). The installation procedure for the extension arm (5) with motor arm (4) or the XL extension arm (5) with motor arm (4) is identical. The figure shows a simplified representation with only the motor arm (4) without cables.

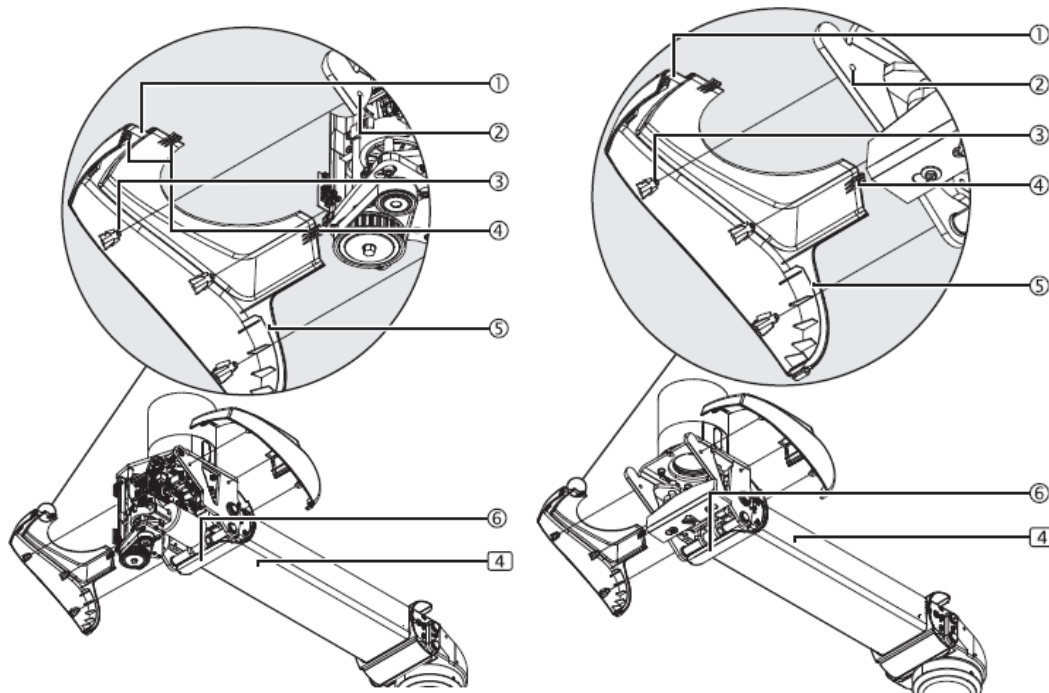

Fig. 53 Mounting of the rear side covers on a motor arm (left) or spring arm (right)

- Fit the first side cover ① and insert 3 plastic pins ③ into the holes ② in the motor arm. Make sure that the protective cover ⑥ protrudes through the guide ⑤ of the first side cover ①.
- Fit the second side cover and insert 3 plastic pins ③ into the holes ② in the motor arm (4).
- The protective cover ⑥ must protrude into the guide ⑤ of the side cover panel ① and the 3 locking devices ④ on the two side covers must engage with each other.
- The side covers must fit tightly together without gaps.

#### 6.9.2.4. Rear bottom cover mounting on a motor or spring arm

The figure shows the motor arm (4). The installation procedure for the extension arm (5) with motor arm (4) or the XL extension arm (5) with motor arm (4) is identical. The figure shows a simplified representation with only the motor arm (4) without cables.



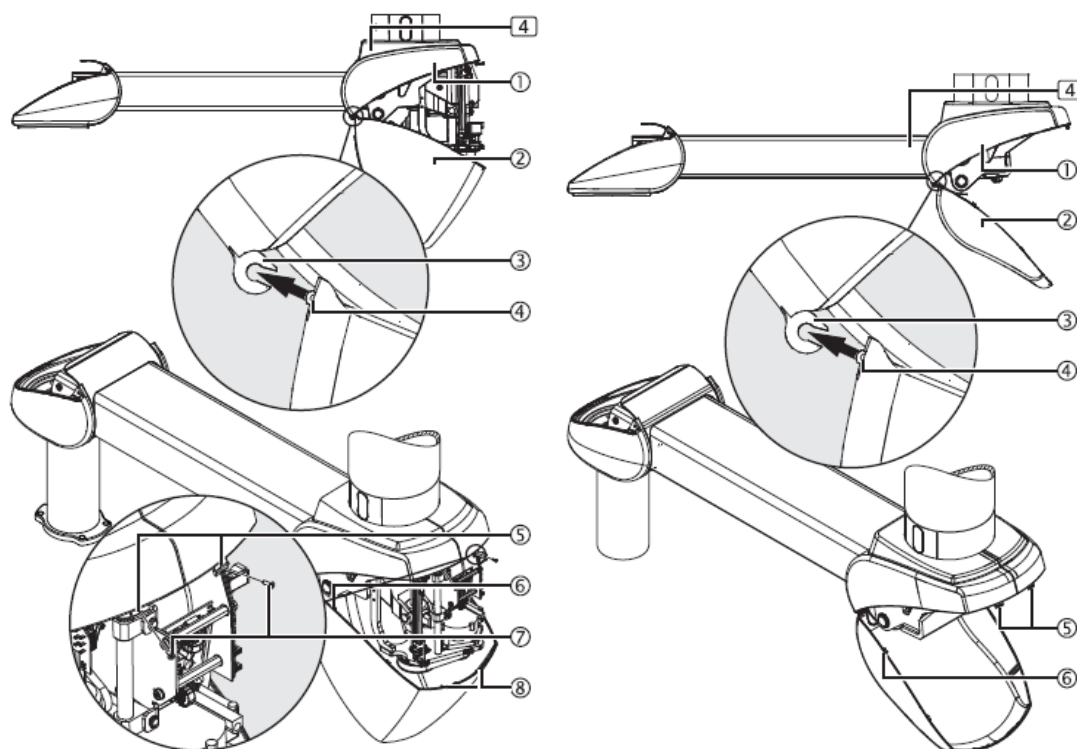

Fig. 54 Mounting the lower rear cover on a motor or spring arm.

- Hold the rear bottom cover (2) at the angle shown in the figure.
- Insert the gasket (4) of the rear bottom cover (2) into the 2 mounting devices (3) of the side covers (1).
- Lift the rear bottom cover (2) so that the 2 latches (5) snap into place.
- Check that the cover (2) is securely in place by verifying that it sits on the side covers (1) without gaps.
- For arm with motor. Insert 2 M3 x 10 mm countersunk Allen screws (7) into the openings (8) of the cover (2) and tighten them.

#### 6.9.2.5. Mounting of front side covers on a motor or spring arm

The figure shows the motor arm (4). The installation procedure for the extension arm (5) with motor arm (4) or the XL extension arm (5) with motor arm (4) is identical. The figure shows a simplified representation with only the motor arm (4) without cables.

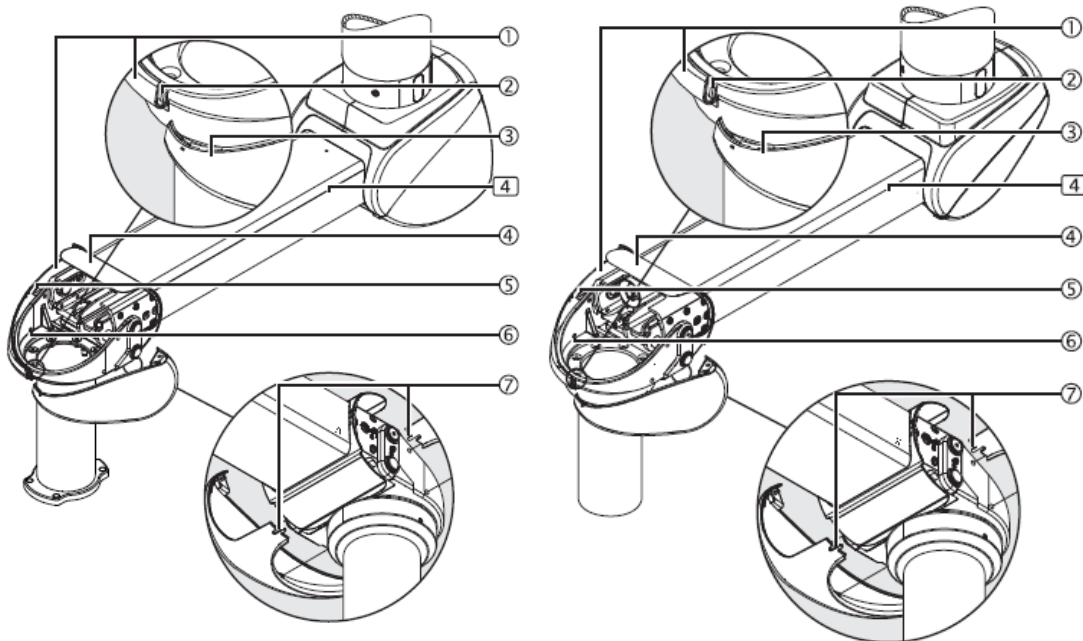

Fig. 55 Mounting the front side covers on a motor or spring arm.

- Fit the right-hand side cover ① and insert 2 plastic pins ⑤ into the holes ⑥ in the motor arm (4).
- Make sure that the cover ④ protrudes into the guide (not shown in the figure) of the side cover ①.
- Attach the left side cover ③ to the mounting fitting ② on the front of the right side cover ①, direct it to the motor arm (4) and then insert 2 plastic pins ⑤ into the holes ⑥ in the motor arm (4).
- Make sure that the cover ④ protrudes into the guide (not shown in the figure) of the side cover ③.
- Gently push the 2 straps ⑦ into the bottom of the side covers and hook them together.
- The side covers must fit tightly together without gaps.

#### 6.9.2.6. Mounting of front top cover on a motor or spring arm

The figure shows the motor arm (4). The installation procedure for the extension arm (5) with motor arm (4) or the XL extension arm (5) with motor arm (4) is identical. The figure shows a simplified representation with only the motor arm (4) without cables.

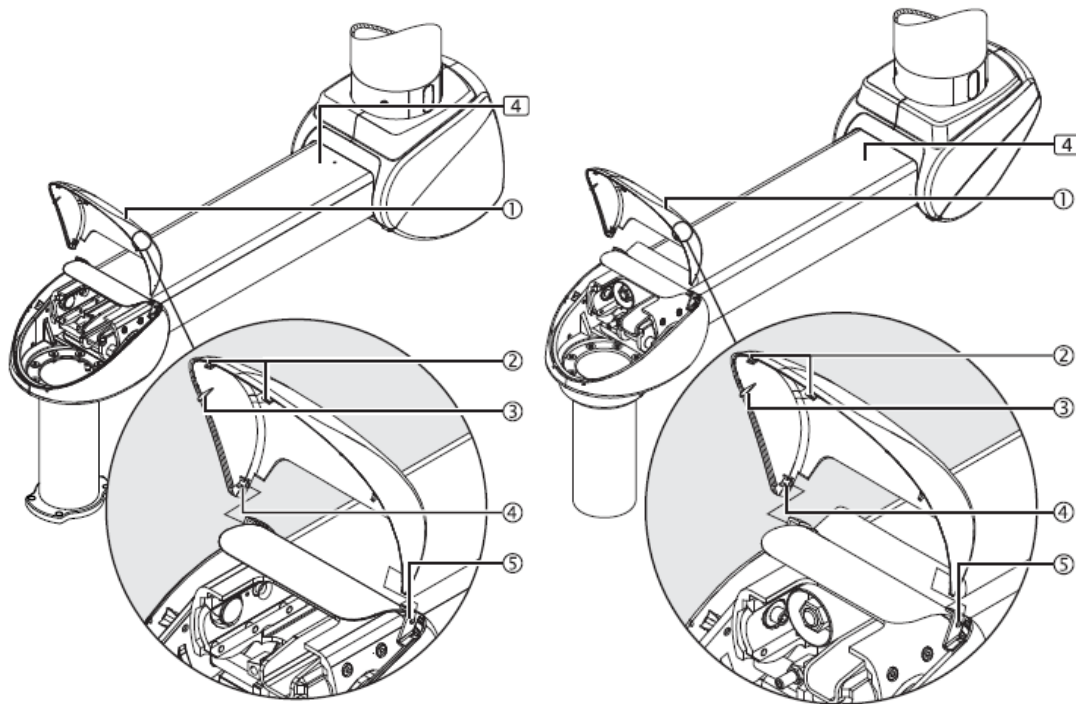

Fig. 56 Mounting the front top cover on a power or spring arm.

- Position the front top cover ① from above and attach one of the 2 shafts ④ to the mounting device ⑤ of the side cover.
- Carefully detach the front top cover ① and attach the second shaft ④ to the mounting device ⑤ of the side cover.
- Lower the cover ① until the 2 latches ② snap into place.
- The front top cover ① must sit on the side covers without gaps.

## 6.10. Adjustments



Disconnect the equipment electrically, as well as any equipment supplied through the service head, before making adjustments to prevent live wires from the installation coming into contact with live parts of the system.

### 6.10.1. Adjustment of the mechanical brake on the arms

In case of failure of the pneumatic (compressed air operated) brakes, additional mechanical brakes (friction brakes) keep the extension arm and motor arm stable. Adjust the braking force in such a way that the motor arm or extension arm remains stable in any position and can still be adjusted conveniently.

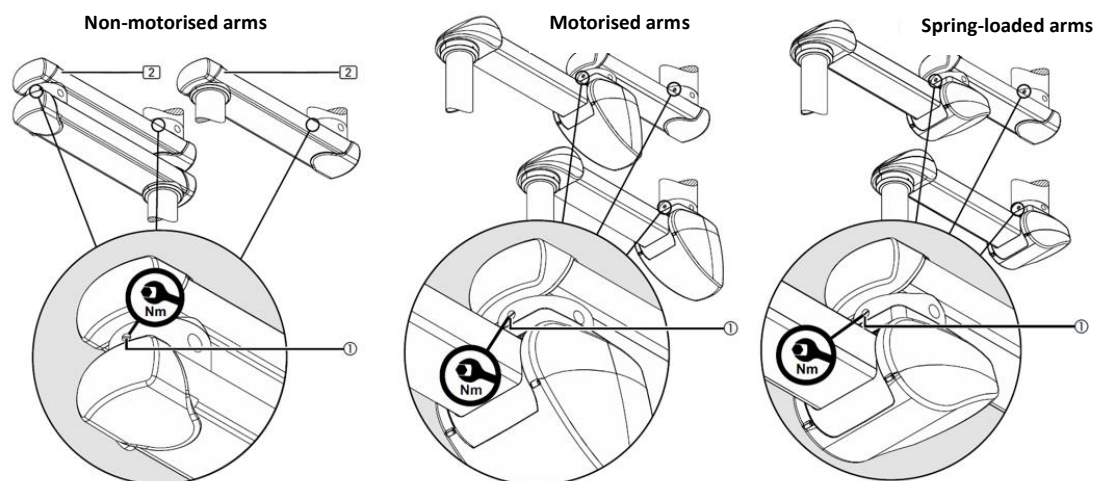

Fig.57 Friction brake adjustment

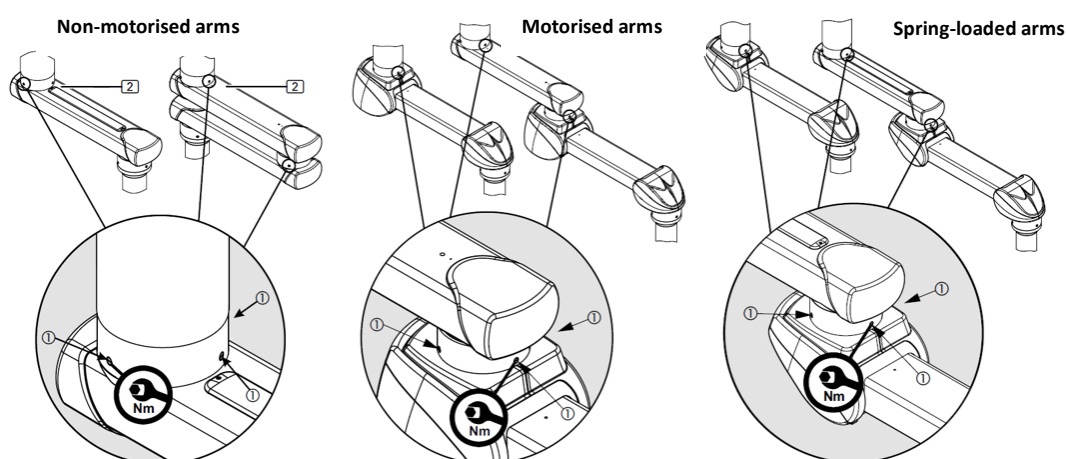

Fig.58 Friction brake adjustment

The mechanical brakes (friction brakes) hold the extension arm (2) in any set position. Adjust the braking force in such a way that the extension arm (2) remains stable in any position and can still be adjusted conveniently.



Risk of collision. If the brakes are not correctly adjusted, the extension arm may automatically move in an uncontrolled manner.

NOTA

Observe the end stop recommendation in chapter 6 and make sure to tighten the brake bolts of the Unit on the roof tube more than at the bearing point of the lower extension arm. This facilitates the bending of the lower extension arm and allows the bearing unit on the lower extension arm to rotate freely.



See section 6.10.4 of this manual.

Use a suitable torque spanner to adjust the brake.

- To increase the braking force, tighten the slotted brake screws (1) by turning them evenly to the right (clockwise). Tighten to 1.6 Nm.
- To reduce the braking force, unscrew the slotted brake screws (1) by turning them evenly to the left (counterclockwise).
- Carrying out a test run

### 6.10.2. Adjustment of the mechanical brake on the drop tube (with bearing)

The brake screw (friction brake) is adjusted in the same way for all different versions of the suspension system. Adjust the braking force of the respective end device so that the end device remains stable in any set position and can still be adjusted comfortably. In the figure below you can see the adjustment scheme for the service head.

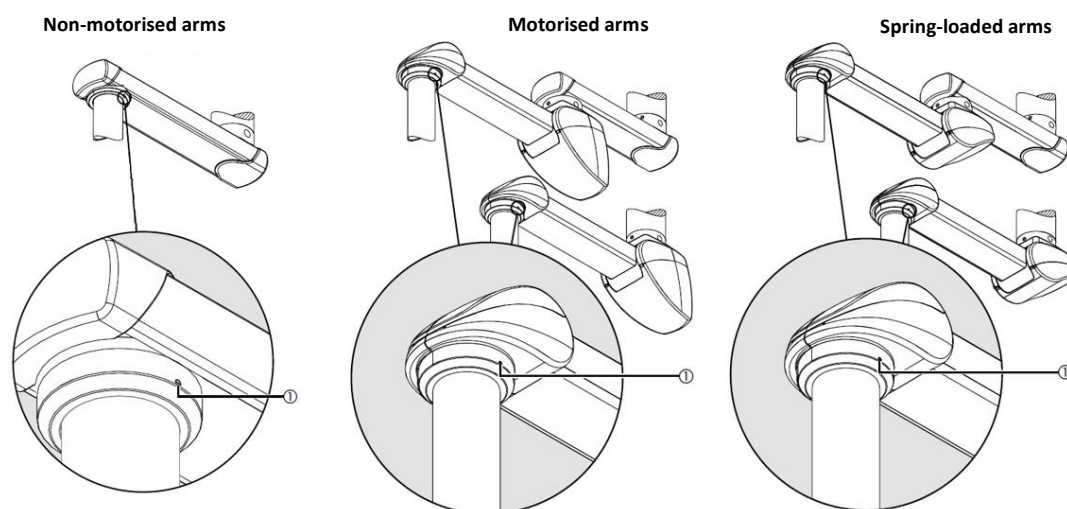

Fig.59 Friction brake adjustment on drop tube with bearing

Use a suitable flat-blade screwdriver.

- To increase the braking force, insert the flat screwdriver into the brake screws (1) and turn it clockwise to the right.
- To reduce the braking force, insert the flat screwdriver into the brake screws (1) and turn it to the left (counterclockwise).
- Carry out a test run.

### 6.10.3. Adjustment of the mechanical brake on the drop tube (with bearing)

The brake screws (friction brakes) are adjusted in the same way for all different versions of the suspension system. In the case of the drop tube with friction bearing unit, the mechanical brakes (1) (3

friction brakes) hold the end device (e.g. the service head) in the set position. Adjust the braking force in such a way that the corresponding end device (e.g. service head) remains stable in any set position and can still be adjusted comfortably.

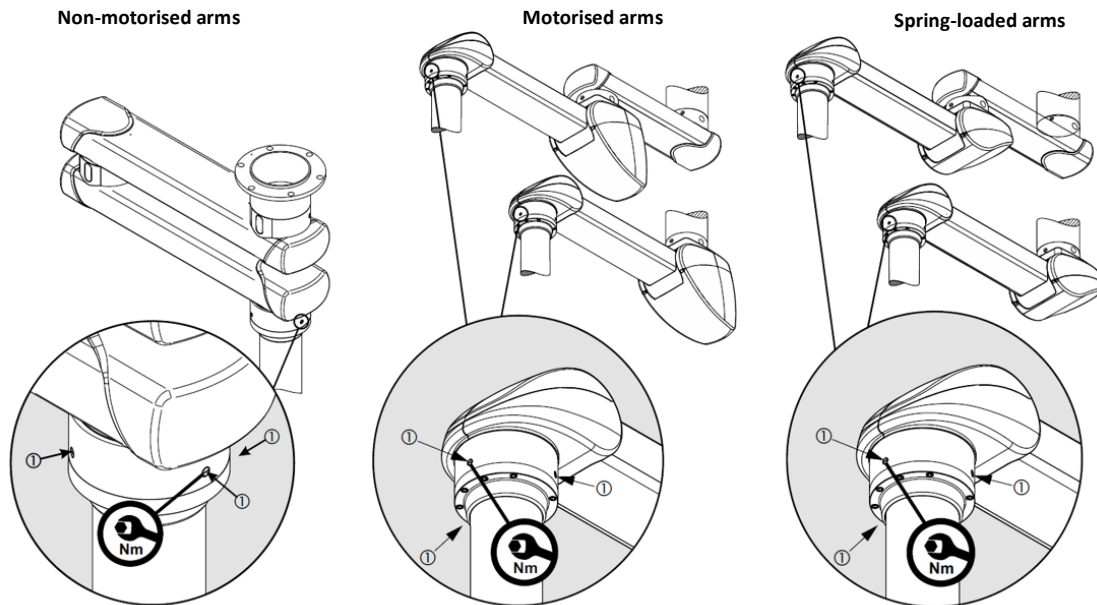

Fig.6.0 Friction brake adjustment on drop tube with bearing

Use a suitable torque spanner to adjust the brake.

- To increase the braking force, tighten the slotted brake screws (1) by turning them evenly to the right (clockwise). Tighten to 1.6 Nm.
- To reduce the braking force, unscrew the slotted brake screws (1) by turning them evenly to the left (counterclockwise).
- Carrying out a test run

#### 6.10.4. Adjustment of the rotary stops

The extension arm and drop tube are equipped with at least 1 ball stop that prevents the internal cables from being destroyed. With 1 ball stop installed, the swivel range is restricted to a maximum of 340 degrees. With 2 ball stops installed, the swivel range can be further restricted.

NOTA

For the version with an inverted arm, 2 ball stops must always be mounted between the extension arms to prevent the extension arms from hitting each other.



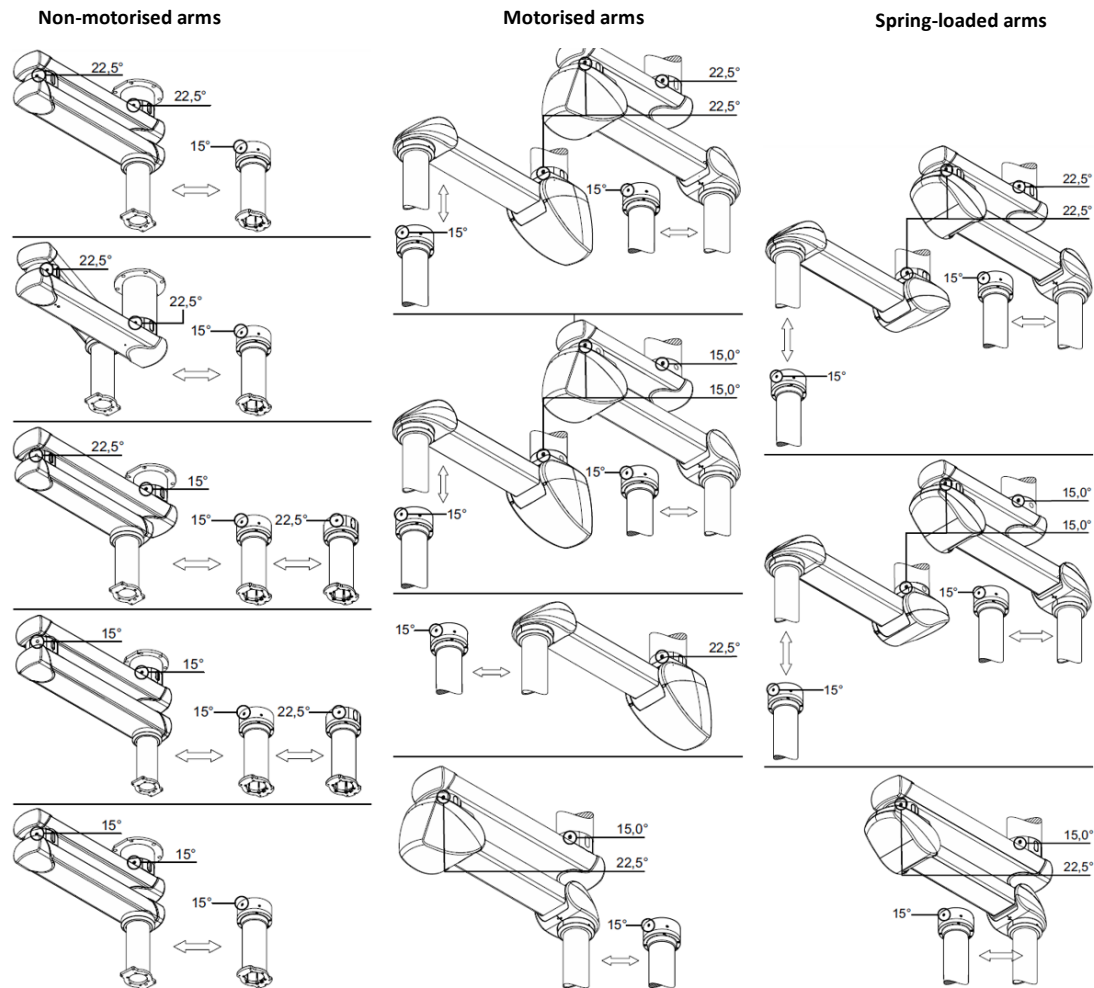

Fig.61 Adjustment of the rotary stops

The swivel ranges of the drop tube and arm versions are different:

- For versions with low load capacity adjust the swivel range of the upper and lower extension arms in increments of 22.5 degrees. Use one M16 fixing screw and two  $\varnothing$  12.7 mm ball stops for each extension arm or motorised arm.
- For versions with medium load capacity set the swivel range of the upper extension arm to 15.0 degree graduations and the swivel range of the lower extension arm to 22.5 degree graduations. Use 1 M20 fixing screw and 2 ball stops  $\varnothing$  16 mm for the upper extension arm. Use 1 M16 set screw and 2 ball stops  $\varnothing$  12.7 mm for the lower extension arm.
- For high load capacity versions, set the swivel range of the upper and lower arms in 15.0 degree increments. Use 1 M20 fixing screw and 2 ball stops  $\varnothing$  16 mm for each arm.
- For versions with pneumatic and friction brake adjust the swivel range of the upper and lower extension arms in 15.0 degree increments. Use 1 M16 fixing screw and 2 ball stops  $\varnothing$  10 mm for each extension arm.

- For versions with drop tube with friction bearing unit (roller bearing) set the swivel range of the console tube in increments of 15.0 degrees. Use 1 M16 fixing screw and 2 ball stops  $\varnothing$  10 mm for each drop tube.
- For versions with electromagnetically braked drop tube, set the swivel range of the bracket tube in increments of 22.5 degrees. Use 1 M16 fixing screw and 2 ball stops  $\varnothing$  12.7 mm for each drop tube.

NOTA

A magnetic pin or similar tool is required to displace the ball stop. Telescopic magnet pick-up tool kit is available as an option.

- For double arm versions with friction bearing in between, it is recommended to fit 2 ball stops (3) (see Fig. 59). The detailed illustration shows the intermediate bearing (11) (without outer ring) and the position of the stop screw (1) in the ball stops (3).

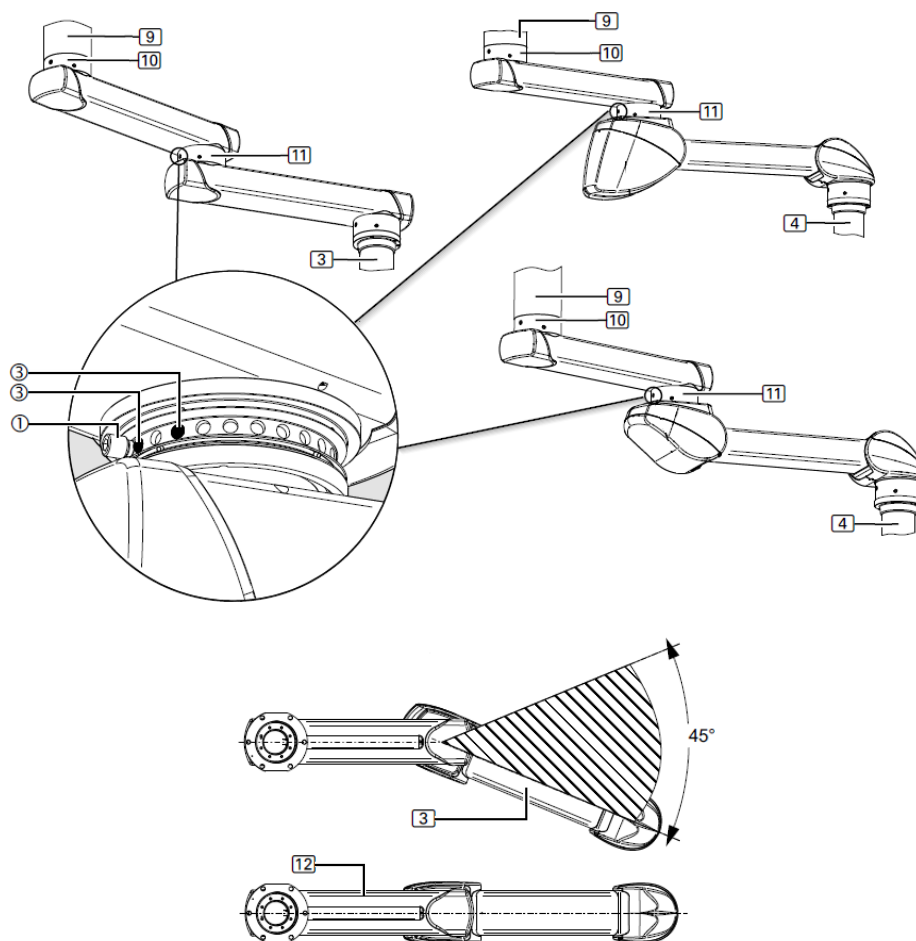

Fig.62 Double double arm system and friction bearing between arms

When adjusting the end stop as illustrated in Figure 62, the dead centre area is 45°. This means that the spring arm (3) has a maximum range of movement of approx. 315°. If the minimum setting on the end stop is not defined while adjusting the brakes on the intermediate bearing (11) and the ceiling



bearing (10), it is quite difficult to bend the suspension system from the stretched position (12) and turn it on the intermediate bearing (11) of the spring arm (3).

When moving the adapter on the drop tube (4) from the extended position (12), there is a risk that the extension arm and spring arm will rotate around the ceiling bearing (10) although it would be desirable to bend in the area of the intermediate bearing (11).

#### 6.10.5. Replacement or disassembly of the rotary stops

The following section describes how to adjust the end stop on the drop tube with friction bearing unit (roller bearing) and on the arms. The procedure for adjusting the end stop is identical for the drop tube with electromagnetic brake unit.

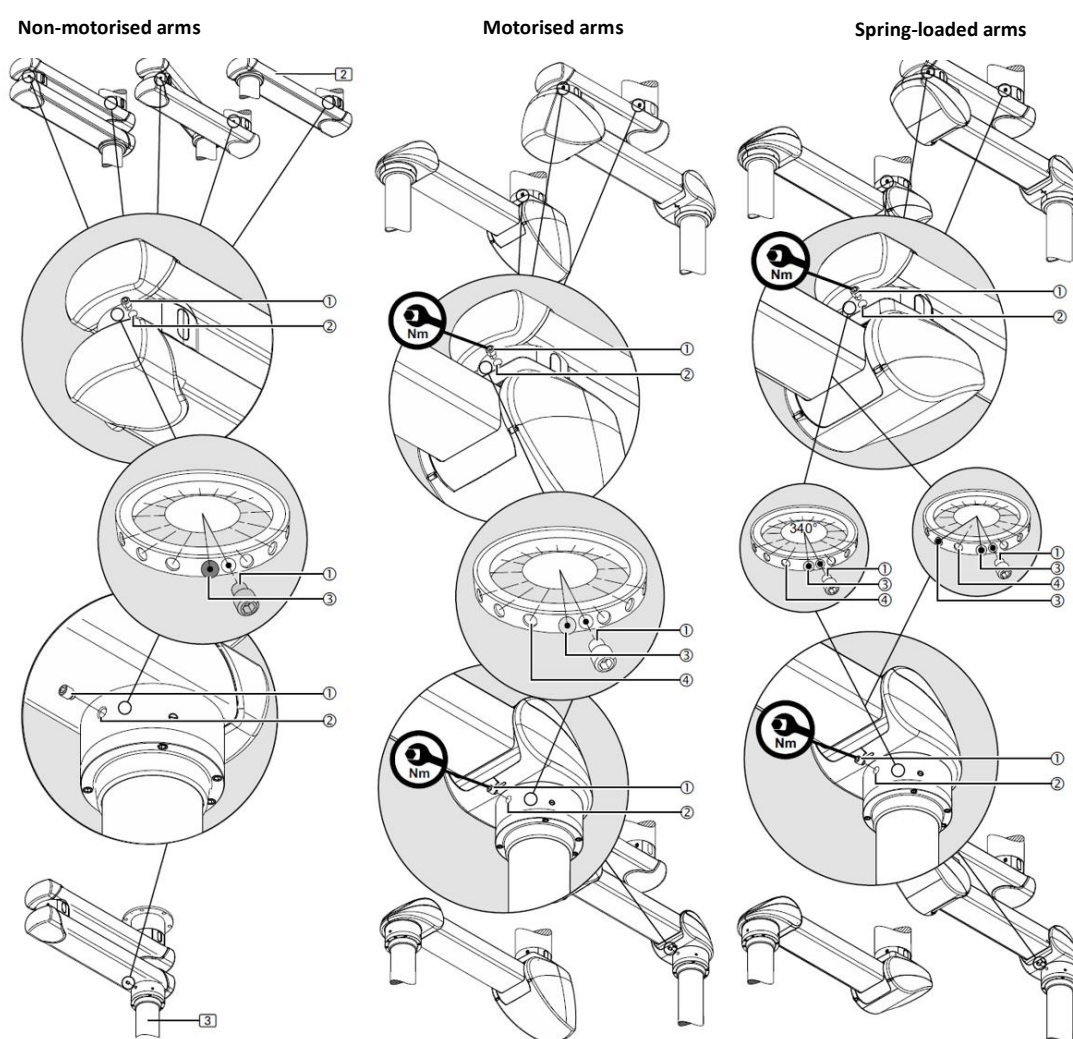

Fig.63 Removing the rotary stops

- Unscrew the fixing screw (1) from the threaded hole (2).
- Rotate the drop arm or drop tube until the ball stop (3) is visible in the threaded hole (2).

- Using a telescopic magnet pick-up tool, remove the ball stop (3) from the threaded hole (2) and store it in a safe place.

### 6.10.6. Assembly of the rotary stops

NOTA

For the inverted arm version, the ball stops must always be mounted between the extension arms to prevent the extension arms from hitting each other.

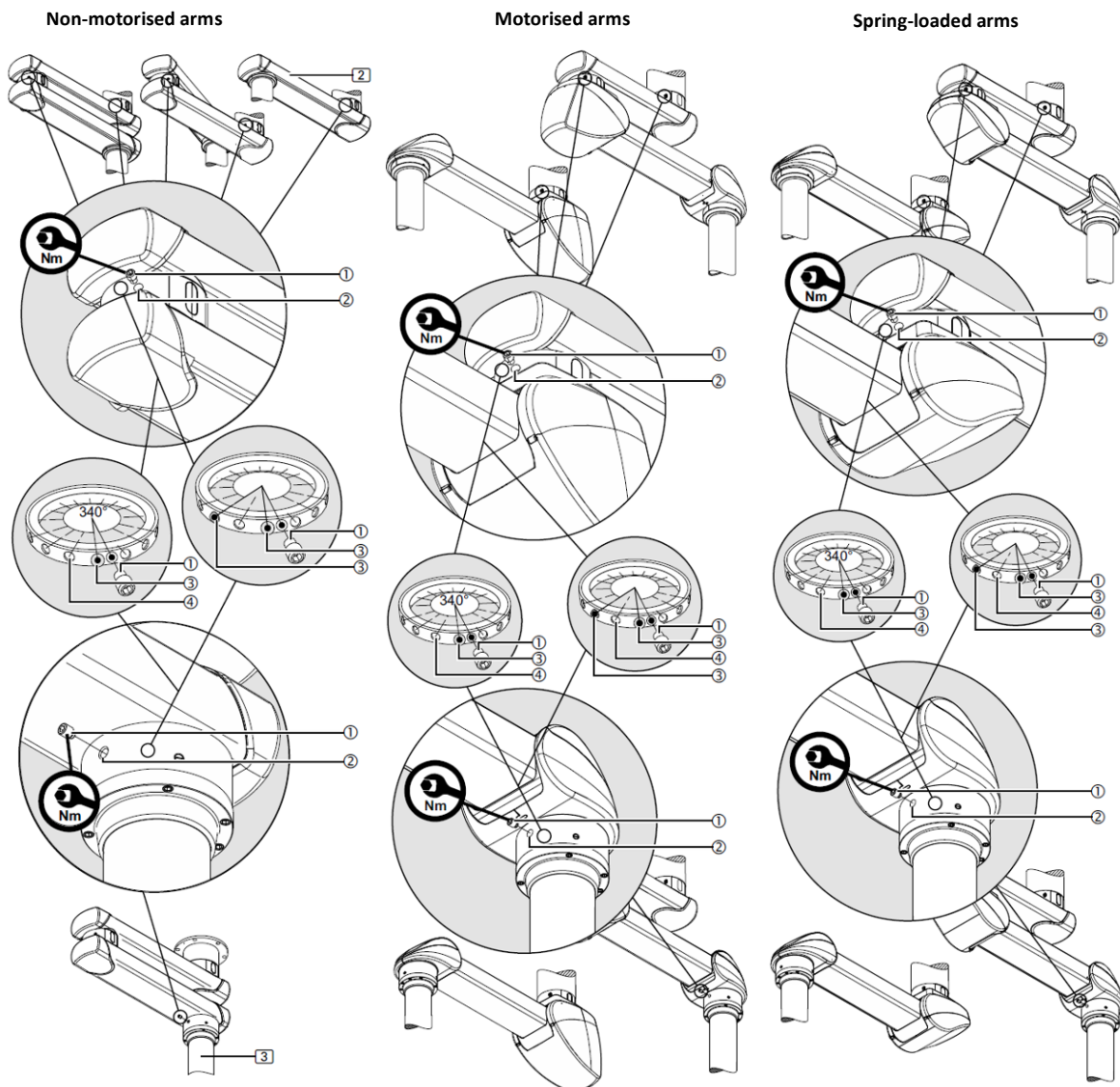

Fig.64 Assembly of the rotary stops

- Rotate the extension arm or console tube to the desired end stop position and then insert 1 ball stop (3) into the threaded hole (2).
- Ensure that the ball stop is firmly in place. The extension arm or drop tube can be rotated once the ball stop (3) has been fully inserted into one of the mounting fittings (4). Otherwise,

these lock and the ball stop (3) must be pushed into one of the mounting fittings (4) while gently turning the extension arm or drop tube with a screwdriver.

- Rotate the extension arm or console tube to the desired position of the second end stop and then insert 1 additional ball stop (3) into the threaded hole (2).
- Slightly rotate the extension arm or drop tube and then screw the set screw (1) into the threaded hole (2) as far as it will go. The set screw (1) now serves as an end stop for the mounted ball stop (3) and restricts the swivel range of the extension arm or drop tube.
- Tighten the set screw (1) to 40 Nm.
- To check that the swivel stop is working properly the swivel range of the extension arm or drop tube must be limited to less than 360 degrees.

### 6.10.7. Vertical lift adjustment on the motor arm

The simplified representation illustrates the extension arm and motor arm without the cables mounted. The adjustment is identical for all versions.

The motor arm has a vertical lift of + 20 degrees in the upward direction and - 30 degrees in the downward direction. The vertical lift can be restricted in both upward and downward direction.

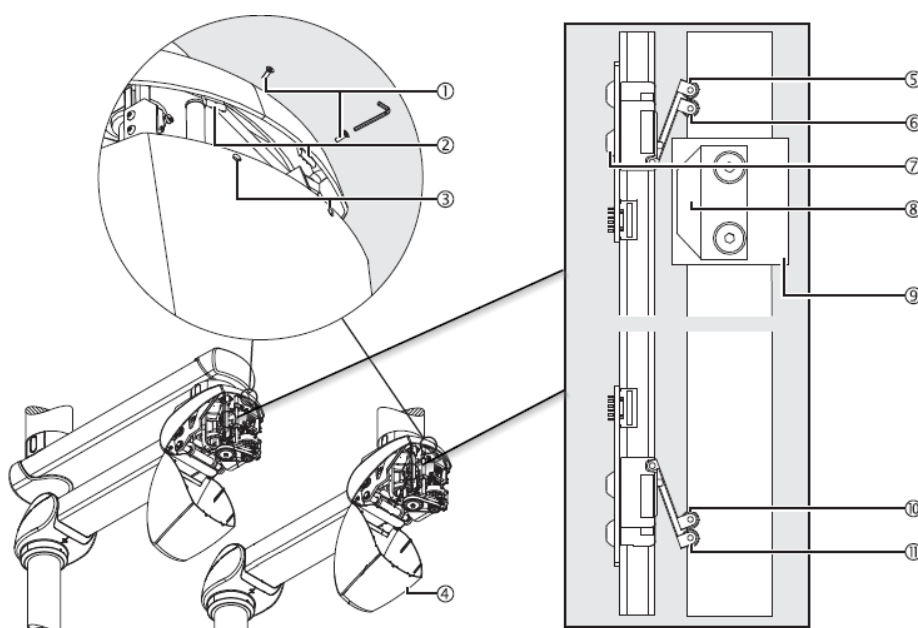

Fig.65 Opening of the lower rear cover and component details

- To adjust the height of the motor arm, the end stop (8) on the ball screw nut (9) is directed towards the 2 upper end switches (5)/(6) and 2 lower end switches (10)/(11) which switch off the motor.

- The end switch ⑥ or ⑩ actuated first by the end stop ⑧ ensures decelerated starting or braking (SoftStart / SoftStop) of the motor.
- The second limit switch ⑤ or ⑪ switches the engine off.
- The upper and lower vertical lifts are adjusted separately and one after the other. To adjust the vertical lift, move the motor arm to the desired upper or lower height position.



Disconnect all poles of the pendant system from the mains and prevent it from being switched on again.

- Use an Allen key (size 2.5) and unscrew 2 M4 x 6 mm countersunk Allen screws ⑦ - ISO 7380 - 10.9.
- Push the circuit board with the end switches ⑤/⑥ towards the end stop ⑧ until the end switch ⑤ or ⑪ audibly engages and then tighten the 2 M4 x 6 mm countersunk Allen screws ⑦ - ISO 7380 - 10.9.



If the motor arm moves without a properly installed limit switch, the motor arm may be damaged and must be replaced.

The vertical lift adjustment may change gradually during operation if the M4 x 6 mm countersunk Allen screws ⑦ - ISO 7380 - 10.9 have not been tightened correctly. In this case, there is a risk of the motor arm hitting the ceiling or other hanging system.



Tighten the M4 x 6 mm countersunk Allen screws ⑦ to 3 Nm.

- Close the lower rear cover ④ as described in the following section and perform a function test.
- Repeat these steps for limit switches ⑩/⑪ if necessary.

#### 6.10.7.1. Opening / closing of the lower rear cover

To open the lower rear cover, use an Allen key (size 2).

- Unscrew the 2 M3 x 10 mm countersunk Allen screws ① from the 2 openings ③.
- Release the 2 latches ②.
- Manually direct the lower rear cover ④ all the way down until it points downwards in a completely vertical position.
- To remove the cover ④, turn it approx. 45 degrees downwards.
- Be sure to pass this position before releasing the cover ④.

To close the rear bottom cover, push it back in until the 2 latches ② snap into place.

- Check that the cover ④ sits on the side covers without gaps.
- Insert the 2 M3 x 10 mm countersunk Allen screws ① into the 2 openings ③ in the cover ④ and tighten them.

#### 6.10.8. Correcting the vertical alignment of the Service Head on a power arm

After mounting an end device (e.g. medical device, etc.), it may be necessary to vertically align this end device.

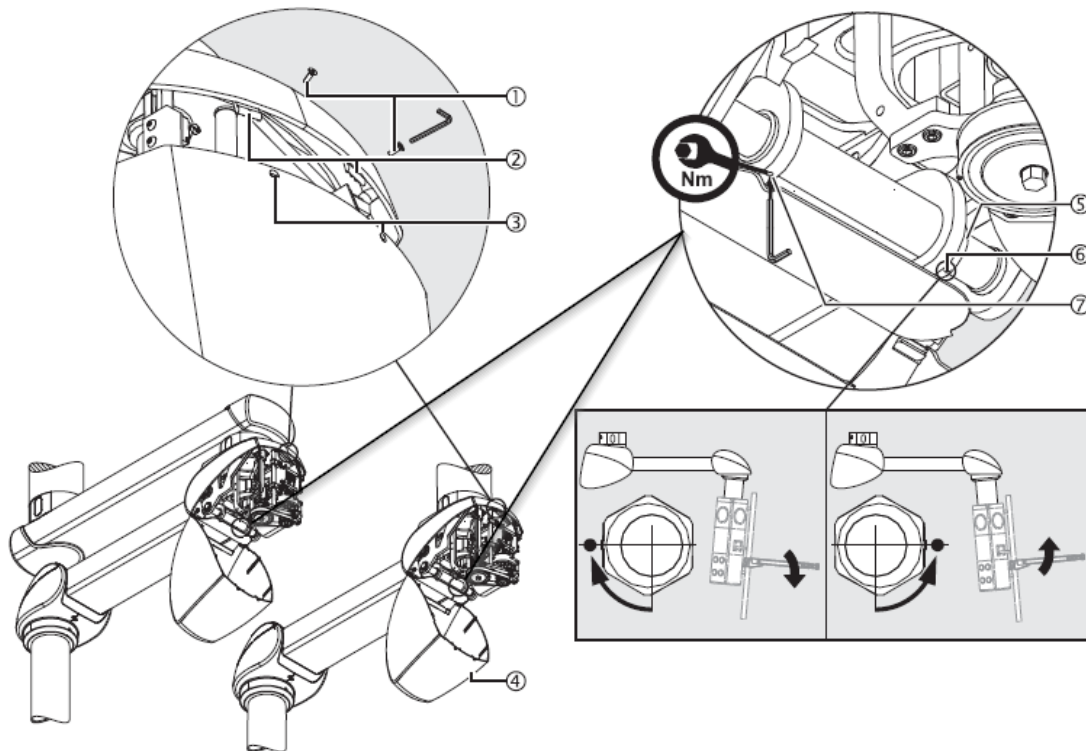

Fig.66 Adjusting the load capacity of the motor arm and closing the rear bottom cover

- Open the lower rear cover as described in paragraph 6.10.7.1 above.
- Use an Allen key (size 4) and a spanner (size 36).
- Loosen the M4 set screw ⑦ - DIN 914 using the Allen key.
- Place the spanner on the hexagonal bolt ⑤.
- The indicator screw ⑥ points downwards (do not loosen this screw).
- To lower the tray in the example shown in Fig. 61, turn the hexagonal bolt ⑤ so that the indicator screw ⑥ points forwards (towards you). See Fig. 61 Detail view, bottom right.
- To lift the tray in the example shown in Fig. 61 turn the hexagonal bolt ⑤ so that the indicator screw ⑥ points backwards (away from you). See Fig. 61 Detail view, bottom right.



- Carry out a test run.
- Tighten the M4 grub screw ⑦ - DIN 914.

The vertical alignment can change progressively during use if the M4 fixing screw ⑦ - DIN 914 has not been tightened correctly. If this happens, the CEMOR service head or monitor bracket no longer remains stable in its adjusted position.



Tighten the M4 set screw ⑦ - DIN 914 to 2 Nm.

- Close the lower rear cover as described in paragraph 6.10.7.1 above.

### 6.10.9. Vertical alignment correction of the CEMOR monitor bracket or Service Head on a spring-loaded arm

After mounting an end device (e.g. flat screen, medical device, etc.) there is a risk that the CEMOR service head or monitor holder is no longer in an exactly vertical position due to the weight of the end device.

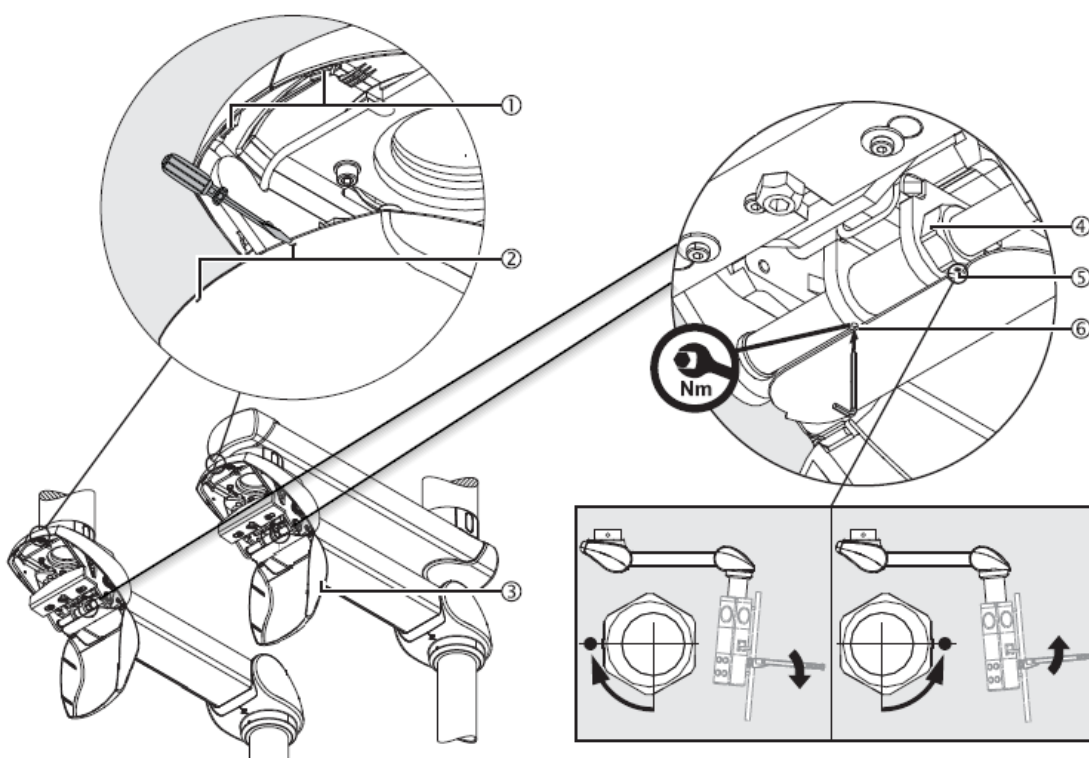

Fig.67 Correcting the vertical alignment of the CEMOR service head or monitor bracket

- Open the lower rear cover as described in 6.9.2 above.
- Use an Allen key (size 4) and a spanner (size 36).
- Loosen the M4 fixing screw ⑥ - DIN 914.

- Place the spanner on the hexagonal bolt ④.
- The indicator screw ⑤ points downwards (do not loosen this screw).
- To lower the tray in the example shown in figure 67, turn the hexagonal bolt ④ so that the indicator screw ⑤ points forwards (towards you).
- To lift the tray in the example shown in figure 67, turn the hexagonal bolt ④ so that the indicator screw ⑤ points backwards (away from you).
- Carry out a test run.
- Tighten the M4 grub screw ⑥ - DIN 914.

The vertical alignment can change progressively during use if the M4 fixing screw ⑥ - DIN 914 has not been tightened correctly. If this happens, the CEMOR service head or monitor bracket is no longer stable in its adjusted position.



Tighten the M4 set screw ⑥ - DIN 914 to 2 Nm.

- Close the lower rear cover as described in 6.10.9.1 above.

#### 6.10.10. Adjusting the load capacity on the spring arm

The simplified representation illustrates the extension arm and the spring arm without the cables mounted. The adjustment is identical for all versions. The spring arm is equipped with 1 or 2 springs which compensate the weight of the CEMOR or the service head with the end device (e.g. flat screen, medical device, etc.).

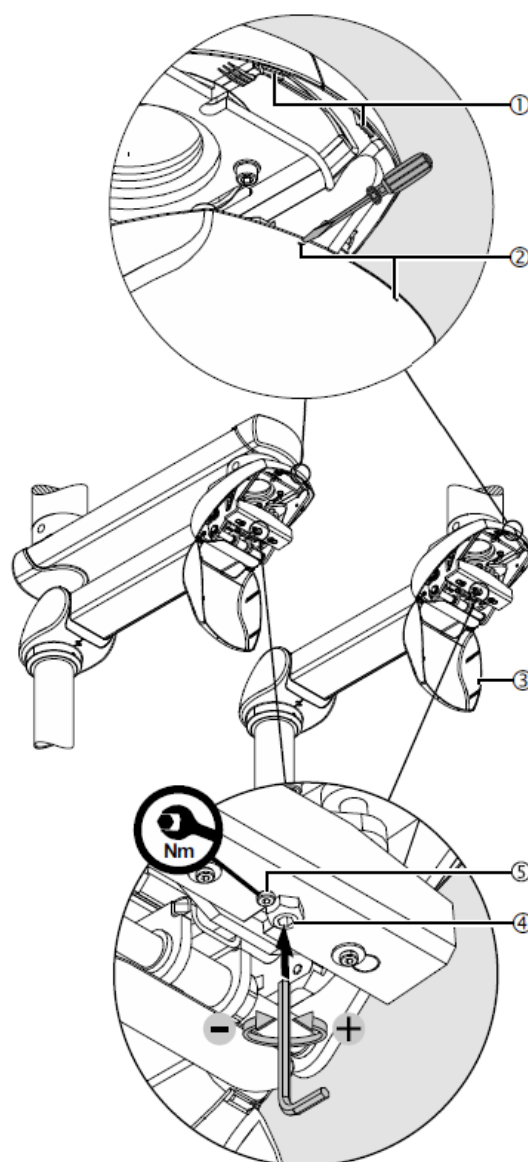

Fig.68 Adjusting the load capacity of the spring arm and rear lower cover lock.

#### 6.10.10.1. Opening / closing of the lower rear cover

To open the lower rear cover

- Insert a suitable screwdriver into the 2 openings ② one after the other and then release the 2 latches ①.
- Fold down the rear bottom cover ③.

To close the rear bottom cover, push it back in until the 2 latches ① snap into place.

- Check that the cover ③ sits on the side covers without gaps.



Adjust the load capacity of the spring arm so that the spring arm with service head or CEMOR monitor holder and the end device (e.g. flat screen, medical device, etc.) remain stationary in any set position.

NOTA

If the spring arm does not remain in position after adjusting the spring tension, the spring arm must be replaced by a service technician.

Possible versions of spring-loaded equipment: 30-60 kg, 50-80 kg, 70-110 kg, 80-135 kg, 120-180 kg.

The load capacity ranges and the maximum load capacity are indicated on the spring arm nameplate.

- Use an Allen key (size 10) and a ring spanner (size 24).
- Unscrew the socket head cap screw M8 x 16 mm ⑤ - DIN 7984 with the ring spanner.
- Insert the Allen key into the set screw ④.
- Raise the spring arm approx. 10 degrees above horizontal (0 degree position) to relieve the tension on the adjusting screw ④.
- If the spring arm moves downwards, the load capacity is too low.
- Turn the Allen key to the left (counterclockwise) as illustrated in the figure.
- If the spring arm moves upwards, the load capacity is too high.
- Turn the Allen key to the right (clockwise) as shown in the figure.
- Carry out a test run.
- Screw in and tighten the socket head cap screw M8 x 16 mm ⑤ - DIN 7984 with the ring spanner.

The setting of the load capacity can change progressively during operation if the socket head cap screw M8 x 16 mm ⑤ - DIN 7984 has not been tightened correctly. If this is the case, the spring arm no longer remains stable in its set position.



Tighten the M8 x 16 mm Allen screws ⑤ to 12 Nm.

### 6.10.11. Adjusting vertical lift on a spring arm

When replacing an end device (e.g. flat panel display, medical device, etc.), the spring arm must be set to a horizontal position (0 degree position).

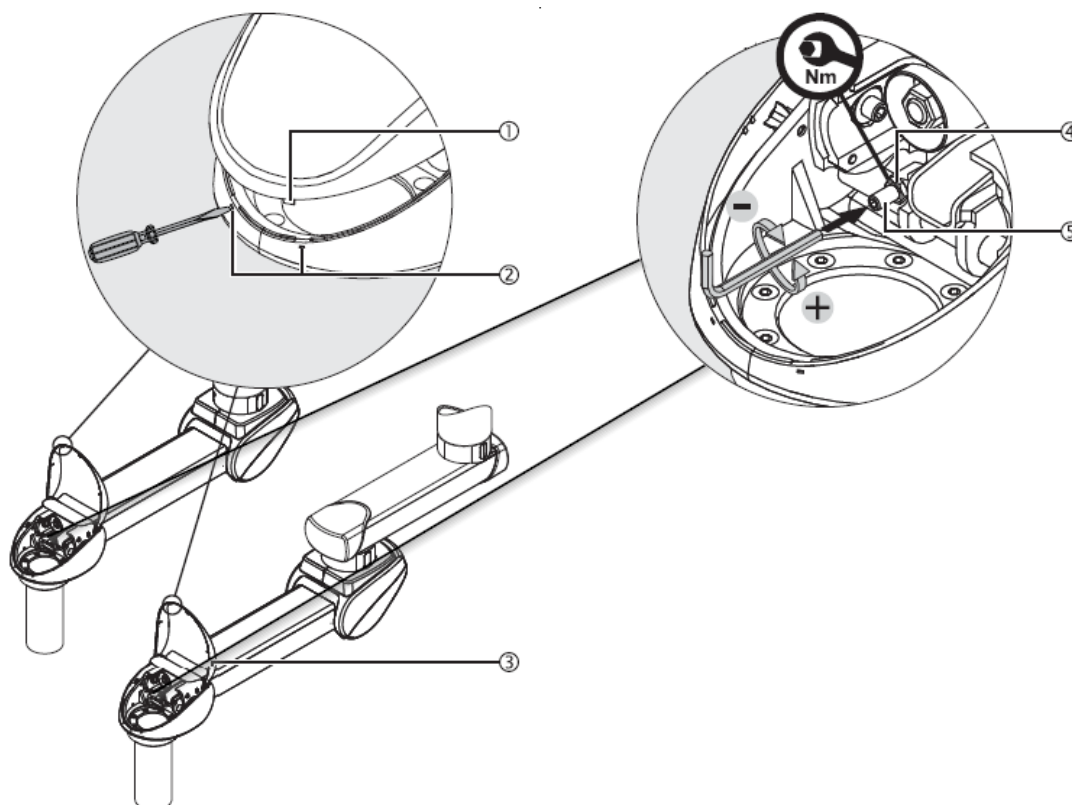

Fig.69 Adjusting the vertical lift on a spring arm

#### 6.10.11.1. Opening/closing of the front top cover

To open the upper front cover

- Insert a suitable screwdriver into the 2 openings (2) one after the other and then release the 2 latches (1).
- Lift the front top cover (3) until it clicks into place.

To close the upper front cover

- Fold down the front top cover (3) so that the 2 latches (1) snap into place.
- Check that the cover (3) sits on the side panels without gaps.

Adjust the vertical lift of the spring arm so that the spring arm with service head or CEMOR monitor holder and the end device (e.g. flat screen, medical device, etc.) remain stationary in the new set position.

- Use an Allen key (size 10) and a ring spanner (size 18).
- Loosen and turn back the M12 hexagon nut (4) - ISO 4035.
- Insert the Allen key into the set screw (5).

- To reduce the vertical lift, turn the Allen key to the left (counterclockwise) as illustrated in Figure 69.
- To increase the vertical lift, turn the Allen key to the right (clockwise) as illustrated in Figure 69.
- Carry out a test run.
- Tighten the hexagon nut M12 ④ - ISO 4035.

The vertical lift may change progressively during operation if the M12 hexagon nut ④ - ISO 4035 has not been tightened correctly. In this case,



If the M12 hexagon nut ④ - ISO 4035 has not been tightened correctly, there is a risk that the spring arm will hit the ceiling or another suspension system.



Tighten the hexagon nut M12 ④ - ISO 4035 to a torque of 30 Nm.

## 7. Installation checks

When making adjustments to the equipment, it is necessary:

- verify that the relevant medical gas shut-off valves are properly closed and ensure that the system cannot be reopened.
- verify that the system is electrically disconnected and take measures to ensure that the system cannot be reconnected.



CAUTION: Failure to comply with this point will cause serious damage.



Before any installation and adjustment work, the pendant system must be disconnected from the mains.

### 7.1. Check the technical characteristics of the equipment to be installed. Weights, torques.

Before proceeding with the installation of the equipment, it must be checked that the surface on which the equipment is to be installed meets the space and resistance requirements according to the characteristics of the equipment in question.



See point 6 of the use and cleaning manual supplied with the equipment.

## 7.2. Check the condition of the cables and hoses in the system and the rotation of the arms.

Before installing the equipment, check that the cables and hoses of the system are not strained or kinked. There is a risk of destroying or damaging the extension arm cables if an extension arm is rotated more than 360 degrees:

- Do not rotate the extension arms more than 350 degrees.
- If necessary, limit the swing range of the arms.



See section 6.10.4 of this manual.

The system is supplied as standard with the 2 ball stops ② and the fixing screw ① pre-assembled.

The swivel range of the arm (4) or the arm (5) is limited to 0 degrees. This ensures that the extension arm and spring arm cannot rotate and that the internal power cables are not broken.

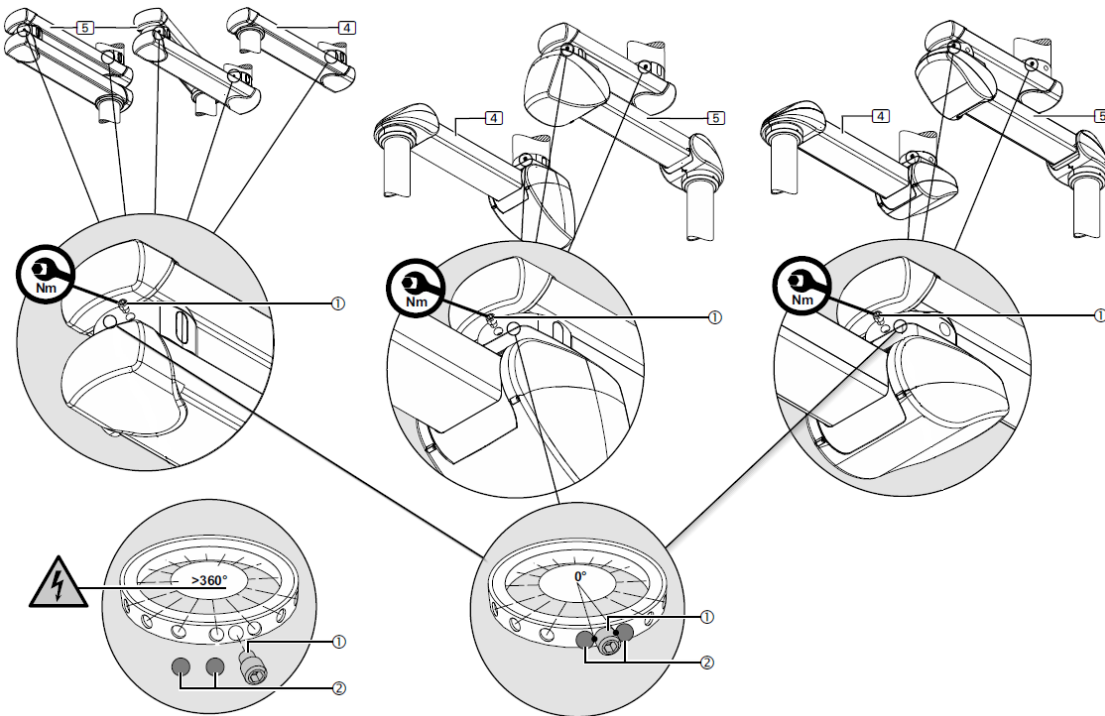

Fig. 70 Swivel stop status

In exceptional cases, the 2 ball stops ② and the set screw ① are delivered as separate components, which means that the arm (4) or the arm (5) can be rotated infinitely more than 360 degrees.



At least 1 ball stopper must be fitted to prevent the internal power cables from twisting.

If no swivel stops have been pre-mounted, the arm (4) and/or the arm (5) must not be swivelled before the swivel stops have been mounted.

- Mount at least 1 ball stop as described in Chapter 6.10.5 to restrict the rotation angle of the arm (4) and/or the arm (5) to 340 degrees.

For adjusting the rotary stops:



See section 6.10.4 and section 6.10.5 of this manual.

### 7.1. Mechanical test

It must be checked that each of the anchorage points is properly fixed to the mounting surface and that there is no displacement of the equipment.



WARNING: Personal injury may result from dropping the equipment.



See section 6.6.5 of this manual.

### 7.2. Check the service head enclosure.

Check that each element of the service head enclosure that has been removed for the installation operations described in this manual is properly fixed and secured in its intended position.

- Checking of openings, closings, foldings, displacements.



See section 6.7 of this manual.



WARNING: The use of gloves is recommended as minor personal injury may occur.

### 7.3. Mechanical crash test

Once the system has been installed, it must be checked to ensure that no collisions can occur with:

- other hanging systems,
- ceilings or walls,
- other equipment

### 7.4. Gas circuit test.

The equipment must be tested according to the current standards, EN ISO 7396-1\_2016 and EN ISO 7396-2\_2007 by qualified personnel.

The medical gas piping system shall be checked:

- Watertightness
- Integrity

- No crossovers between circuits.
- Good functioning of the gas intakes

These tests shall be carried out at operating pressure.



CAUTION: Danger of impact of a metallic element due to faulty disconnection, can cause serious personal injury.

### 7.5. Electrical circuit tests.

Once the equipment has been installed, power must be supplied to each of the circuits provided and a test must be carried out to check that all the mechanisms provided in the circuit in question, and only these, are supplied with voltage.

- Check continuity of protective earth wiring.



DANGEROUS VOLTAGE: To avoid risk of electric shock, equipment must be connected to a protective earth. Failure to do so may result in personal injury.

## 8. Regulations

### 8.1. Team ranking

According to the new **MDD** regulation **93/42/EEC** concerning medical devices, this product family is classified as:

- Class IIb, by Annex II, excluding section 4, regulation 11.
- IP20 protection level according to IEC 60529.

Equipment intended for continuous operation.

### 8.2. Reference standards

The device complies with the safety requirements of the following standards and directives:

ISO11197: Medical supply units.

IEC 60601-1: Medical electrical equipment. General requirements for basic safety and essential performance.

IEC 60601-1-2: Medical electrical equipment. Part 1-2. General requirements for basic safety and essential performance. Collateral standard. Electromagnetic disturbances.