

tediselmedical

ATLAS

INSTALLATION MANUAL



tediselmedical.com

CE 0197

Content

1.	Manufacturer	4
2.	Security information.....	4
2.1.	Injury risk warnings.....	4
2.2.	Warnings of risk of damage	4
2.3.	Supplementary symbols used in the safety instructions	5
2.4.	Indication of additional information.....	5
2.5.	Proper use of oxygen.	5
2.5.1.	Oxygen explosion.....	5
2.5.2.	Fire hazard	5
2.6.	Patient environment.....	6
2.7.	Combination with products from other manufacturers.	6
3.	Risks.....	7
3.1.	Gas explosion	7
3.2.	Risk of device malfunction	7
3.3.	Risk of patient contamination and infection.....	7
3.4.	Fire risk.....	7
3.5.	Danger of electric shock.....	7
3.6.	Risk of collision	8
3.7.	Risk of system crash due to overload	8
3.8.	Risk of system crash due to poor installation	8
4.	Symbols used	8
5.	Installation requirements	11
5.1.	Equipment required for installation	11
5.2.	Training	12
6.	Installation and connection	12
6.1.	Installation recommendations	12
6.2.	Installation references	13
6.3.	Loading data	14
6.4.	Mounting of threaded bolts on the interface plate	16
6.4.1.	Installation without false ceiling.....	16
6.4.2.	Mounting with false ceiling	17
6.5.	Mounting the downpipe on the interface plate.....	18
6.6.	Disassembly and assembly of covers.....	19

6.6.1.	Disassembly and assembly of upper decks	19
6.6.2.	Disassembly and assembly of side walls	19
6.7.	Installation of a section of the main body on two downpipes.....	20
6.8.	Assembly of a trolley	21
6.9.	Cable / Pipe entry	22
6.9.1.	Preparation of supply lines.....	23
6.9.2.	Gas piping and anaesthetic gas evacuation installation	24
6.9.3.	Connection of the different electrical circuits.....	25
6.10.	Limit switch adjustment for element carriages.....	26
7.	Installation checks.....	28
7.1.	Check the technical characteristics of the equipment.	28
7.2.	Mechanical test	28
7.3.	Mechanical crash test.....	28
7.4.	Gas circuit test.....	29
7.5.	Electrical circuit tests.....	29
8.	Regulations.....	29
8.1.	Team ranking.....	29
8.2.	Reference standards.....	30

1. Manufacturer

Manufacturer: TEDISEL IBÉRICA S.L.

Address: C/ Sant Lluc, 69-81. 08918 - Badalona (Barcelona) SPAIN

Tel. +34 933 992 058

Fax +34 933 984 547

tedisel@tedisel.com

www.tediselmedical.com



2. Security information

Important notes in these operating instructions are marked with graphic symbols and signal words.

2.1. Injury risk warnings

Signal words such as DANGER, WARNING or CAUTION describe the degree of risk of injury. The different triangular symbols visually emphasise the degree of danger.



WARNING

Refers to a potentially hazardous situation which, if not avoided, could result in death or serious injury.



CAUTION

Refers to a potential hazard which, if not avoided, may result in minor or slight injury.



DANGER

Refers to an immediate danger which, if not avoided, will result in death or serious injury.



Risk of finger entrapment

2.2. Warnings of risk of damage

The signal word WARNING describes the degree of risk of material damage. The triangular symbol visually emphasises the degree of danger.

Damage to surfaces: warns of damage to surfaces due to unsuitable cleaning agents and disinfectants.



NOTICE

Refers to a potential hazard which, if not avoided, may cause damage to the equipment.

2.3. Supplementary symbols used in the safety instructions



Fire hazard



Explosion hazard: warns of ignition of explosive gas mixtures.



Dangerous voltage: warns about electric shocks that can cause serious injury or death.



Failure of the roof support system



Risk of collision

2.4. Indication of additional information

NOTA

A NOTE provides additional information and useful tips for the safe and efficient use of the device .

2.5. Proper use of oxygen.

2.5.1. Oxygen explosion



Oxygen becomes explosive when it comes into contact with oils, greases and lubricants.

Compressed oxygen presents an explosion hazard:

- Make sure that oxygen and gas outlets are free of oil, greasy materials and lubricants!
- Do not use cleaning agents containing oil, grease or lubricants.

2.5.2. fire hazard



DANGER: Escaping oxygen is combustible:

- Open fire, red-hot objects and open light are not allowed when working.

with oxygen!

- Don't smoke!

2.6. Patient environment

The dimensions in the figure below illustrate the minimum extent of the patient environment in an unrestricted area according to IEC 60601-1.

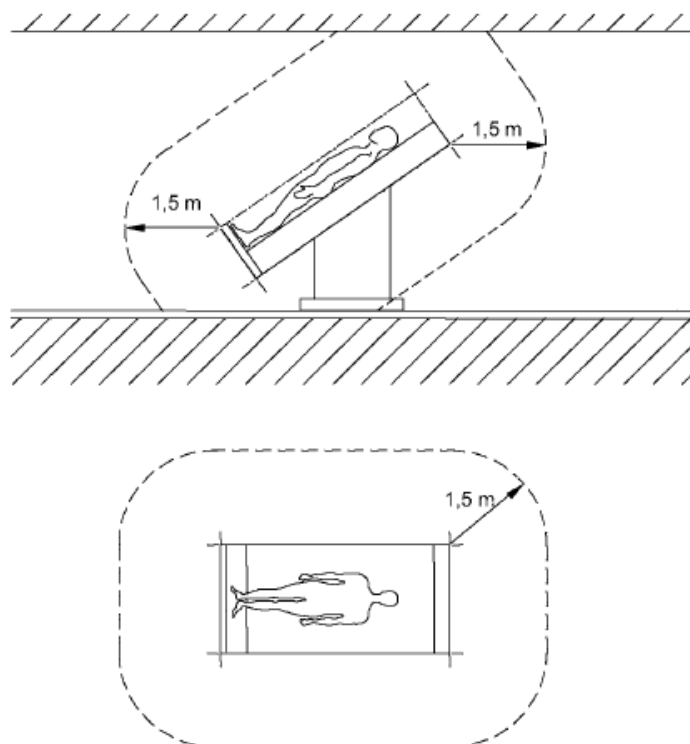

Fig. 1 Minimum extent of the PATIENT ENVIRONMENT

2.7. Combination with products from other manufacturers.

The suspension system is combined with the service head. To avoid dangerous overloads, which can damage or cause collapse of the service head and the pendant system, the specified maximum load capacity must be observed.



See section 6.7 of the user and cleaning manual supplied with the equipment.

Power supply packages intended to supply power to end devices must ensure electrical isolation and provide two protective measures according to IEC 60601-1.

NOTA

The party putting the device into operation is responsible for the validation of the whole system. If necessary, a conformity assessment procedure shall be performed and a

declaration of conformity with Article 22 of the Medical Devices Regulation (EU) 2017/745 shall be provided.



Read the Operating Instructions provided by the external manufacturer to obtain the necessary information for the operation of the end device.

3. Risks

3.1. Gas explosion



Oxygen becomes explosive when it comes into contact with oils, greases and lubricants.

When in contact with oxygen in the air, medical gases may form an explosive or easily flammable gas mixture. The equipment is not suitable for use in environments containing flammable mixtures of anaesthetics with high concentrations of oxygen or nitrous oxide.

If such high concentrations of flammable mixtures of anaesthetics with oxygen or nitrous oxide occur in the environment of the device, there is a risk of ignition under certain conditions.

3.2. Risk of device malfunction



CAUTION: If a device is connected to the equipment and trips the protection mechanism of the corresponding circuit in the health care facility, other devices connected to the equipment will not receive power.

3.3. Risk of patient contamination and infection



WARNING: Parts of the pendant system and adaptations are made of plastic. Solvents can dissolve plastic materials. Strong acids, bases and agents with an alcohol content of more than 60 % can cause plastic materials to become brittle. Dislodged particles may fall into open wounds. If liquid cleaning agents are allowed to penetrate the suspension system and adaptations, excess cleaning fluid may drip into open wounds.

3.4. Fire risk



Plug-in connections for the supply of medical gases must not come into contact with oil, grease or flammable liquids.

3.5. Danger of electric shock



Signal cables (network, audio, video, etc.) must be electrically isolated from equipment and building connection ends to prevent contact with currents that can cause serious injury or death.

3.6. Risk of collision



In the event of a collision with other devices, walls or ceilings, the pendant system and service head may be damaged and important patient care systems may fail, after a collision, the service head and pendant system should be inspected for damage.

3.7. Risk of system crash due to overload



The dead weights of all attached components and the weight of the attached loads must not exceed the maximum load weight of the base support unit.



If the maximum load capacity has been exceeded, there is a risk that the suspension system or components of the suspension system may become detached from the securing device and fall.

- The maximum load capacity of the suspension system and its components must not be exceeded!



See point 6 of the user and cleaning manual supplied with the equipment.

- Do not attach or mount any additional loads on the extension arms, service head and end devices.

3.8. Risk of system crash due to poor installation



If the fasteners of the individual parts of the system are not correctly positioned or if the tightening torques of the fasteners are not observed, the suspension system may come loose from its fastenings and fall down.









4. Symbols used



Applicable part B



Earth (mass)

	Equipotentiality
	Protective earth (ground)
N	Connection point for neutral conductor
	Nurse call button
	Direct lighting
	Indirect lighting
	Operating instructions
MD	Health Product
	Waste electrical equipment
 0197	CE symbol
REF	Product code



Unique identification code



Serial number



Manufacturer



Date of manufacture



Reference to the instruction manual



Damage to surfaces



Fire hazard



Danger of explosion



Dangerous tension



NOTICE

Notice



Risk of finger entrapment

Warning



WARNING



CAUTION

Caution



DANGER

Danger

5. Installation requirements

5.1. Equipment required for installation

- Lifting device or forklift with a permissible payload of at least 250 kg. Alternatively, a lifting winch with a permissible payload of at least 250 kg may be used if space is limited:



CAUTION

Check that the suspension system is sufficiently secured before lifting.



WARNING

During the lifting movement, be sure to avoid collisions with other suspension systems, devices, ceilings or walls and other assemblies.

- Protective gloves
- Digital spirit level
- Torque spanner
- Multimeter
- Standard tool kit
- Spanner 36
- 1 set of telescopic magnet pick-up tools
- Working platform (e.g. pedestal ladder) in accordance with country-specific occupational safety and health standards

5.2. Training

The personnel performing the INSTALLATION must be properly trained and qualified by the customer. The equipment must only be INSTALLED by authorised personnel. Persons who:

1. have received training and are duly registered (at those levels where legal provisions make such registration necessary).
2. have been instructed in the installation of this device by means of this instruction manual as a basis.
3. are able to assess the tasks they perform on the basis of their own professional experience and training in relevant safety standards and can recognise the potential hazards involved in the work.

6. Installation and connection

6.1. Installation recommendations

Figure 2 shows a configuration of the equipment. The most common measuring ranges for each of the dimensions specified in the figure are given below.

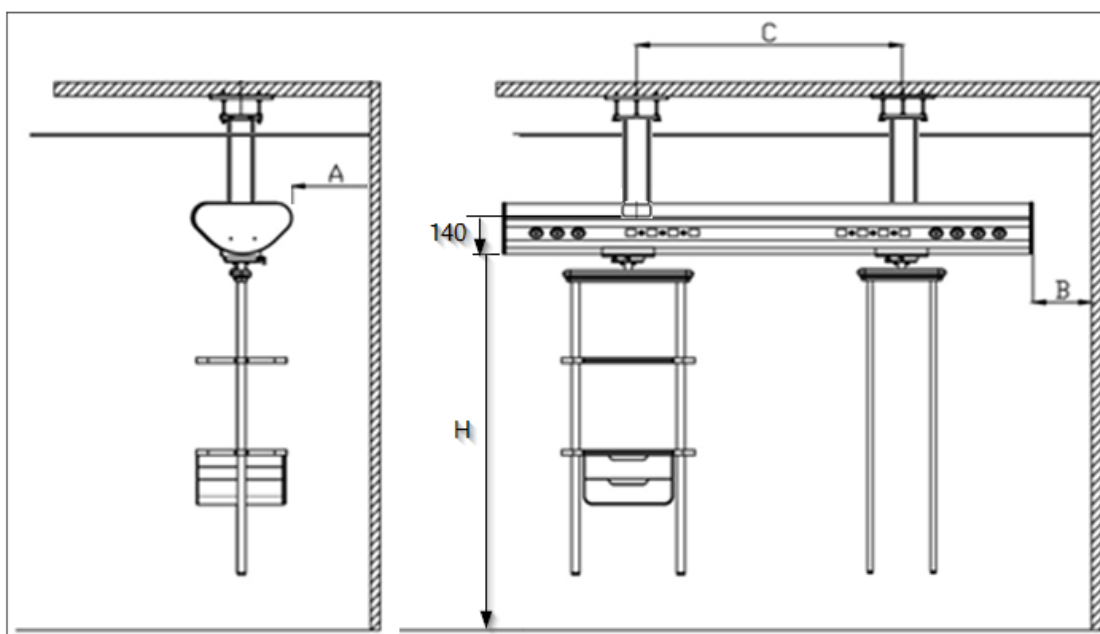

Fig. 2 Recommendations for installation

Measure	Description	
A	Wall clearance parallel to the main body of the equipment (mm)	Min 276
B	Wall clearance perpendicular to the main body of the	Min 350

	equipment (mm)	
C	Distance between supports to ceiling per bed (mm)	Max 1500
H	Ground clearance (depending on the project)	Recommended 1900

The location of the headrest inside the box depends on the requirements of the project, and this section only shows the recommendations of minimum distances to be respected to ensure proper ergonomics and maintenance.

- Check that the position of the ATLAS anchor point does not impede any other installation or component between the suspended ceiling and the floor slab.

The anchor bolt must be fixed to the floor slab as previously defined in the project drawings.



See the installation drawings supplied with the equipment.

6.2. Installation references

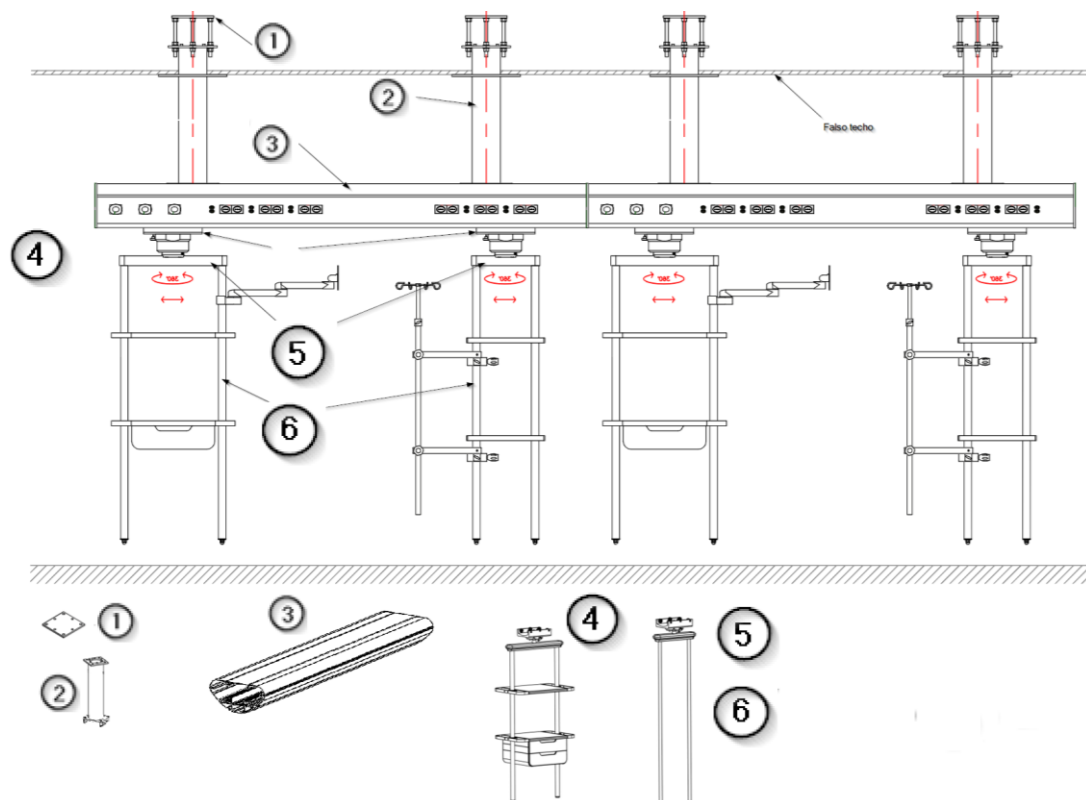





Fig. 3 Installation references

1	Interface plate - pre-assembled (one per downpipe)
2	Downpipe (Including trim) - (two per main body section)
	See point 6.5 of this manual

Material included: 4 rod M16 8.8 (length 350mm) 12 nut DIN934 for M16 12 washer DIN125 for M16 12 washer Grower DIN127 for M16	
3	Main body (suspended head section)
 See section 6.7 of this manual Material included: <ul style="list-style-type: none"> - Main body chassis (as many as sections) - Side walls (pre-assembled) quantity depending on the project. - 8 rod M8 8.8 (length 80mm) - 8 spring washer NFE 25511 for M8 (8.2 x 18 x 1.4) - 8 nut DIN934 for M8 - 8 spacer sleeves for downpipe anchorage - 4 plates for downpipe anchorage 	
4	Trolley - depending on version (not including accessories)
 See manufacturing drawing accompanying the equipment and point 6.8 of this manual. Material included: <ul style="list-style-type: none"> - 1 element carrier (length of trapezoid specified in the order) - 1 tube carrier trapeze ⑤ (on request) - 2 tubes diameter 38 ⑥ element holder (on request) - 2 limit switches (pre-mounted on main body) - Other accessories not included 	

6.3. Loading data

The data required for the calculation of the ceiling load are given in the following tables. When mounting the suspension system, the vertical weight force of the ceiling assembly (the values correspond to the maximum load) must be added to the corresponding values of the suspension system to determine the ceiling load.



The safety factors prescribed in the individual regions must be taken into account when calculating the maximum load data!

The table shows the values for the maximum permissible load capacity of the suspension system. The load data of a version can be calculated from the sum of the individual versions.

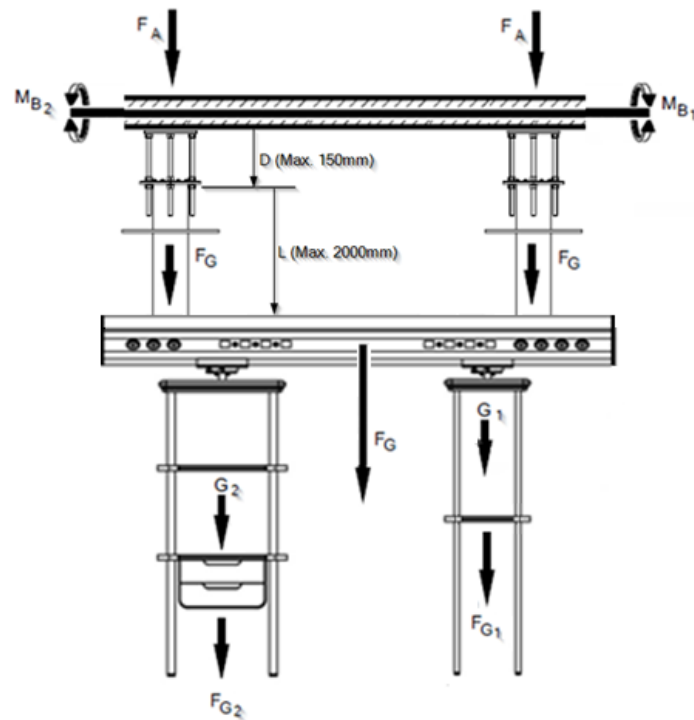

Fig. 4 Load calculation scheme for ATLAS

Suspended headboard	Weight (FG) [N] [N]	Weight (FA) [N] Anchor kit	Max. bending moment MB [Nm] [Nm] [Nm]	Load G [kg]
Downspout. Connecting elements	-	155	-	-
Downspout. Vertical section (L=1000mm)	84.5	-	-	-
Main body. Chassis length 1000mm	340	-	-	400
Main body. End walls	40	-	-	0
Trolley for elements	Weight (FG) [N] [N]	Weight (FA) [N] Anchor kit	Max. bending moment MB [Nm] [Nm] [Nm]	Load G [kg]
Trapeze trolley 300m	170	-	225 (*)	150
Trapeze trolley 500m	170	-	375 (*)	150
Trapeze trolley 700m	190	-	525 (*)	150

NOTA

(*) It considers the maximum load of a trolley applied on one of its tubes and the longitudinal axis of the trapezium perpendicular to the axis of the main body.

6.4. Mounting of threaded bolts on the interface plate

6.4.1. Installation without false ceiling

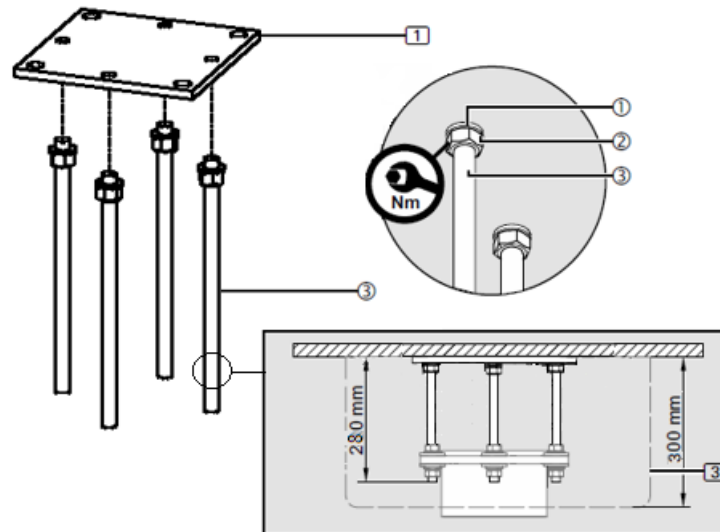

Fig. 5 Mounting of interface plate without false ceiling

- Cut threaded bolts (3) to length

If an interface plate (1) is mounted on the intended slab or structure, the threaded bolts M16 x 350 mm (3) must be cut to size.

- The ceiling trim (3) is later mounted flush with the ceiling and covers the counter plate (4). See figure 12.
- For the ceiling trim (3), which has a height of 300 mm, the 6/12 M16 x 350 mm threaded bolts (3) must be cut to 280 mm. See Fig. 5.
- Lightly deburr the M16 x 350 mm threaded bolts (3) to ensure maximum thread engagement in the interface plate (1).
- Thread 1 M16 hex nut (2) each onto the M16 threaded bolts (3) and then fit 1 spring washer (1) each.



If the M16 threaded bolts (3) (3) are not completely screwed in, they may come out of the interface plate (1) and cause the system to fall down.

- Check that the shortened M16 threaded bolts (3) are securely fastened at the correct distance from each other and fully screwed into the interface plate 1.



The M16 hex nuts (2) must be tightened to 195 Nm.

6.4.2. Mounting with false ceiling

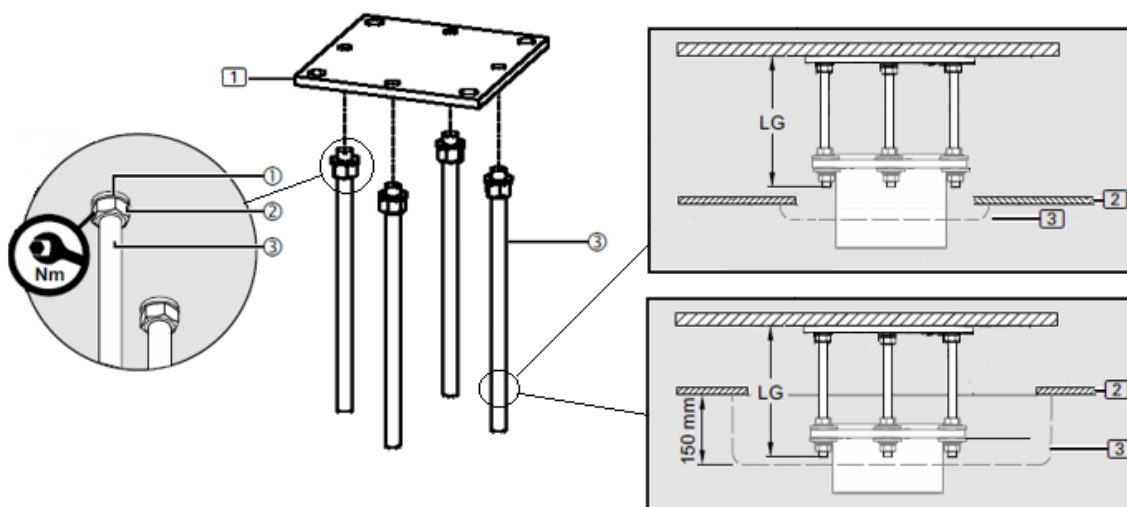

Fig. 6 Installation of interface plate in room with false ceiling

There are two different configurations if a downpipe is installed in a room with a false ceiling. One possibility is that the distance between the floor and the false ceiling completely covers the length LG of the threaded bolts (3), in this case a flat ceiling trim with a height of 10mm is supplied as shown in the upper right part of figure 6. The other possibility is that the distance between the floor and the false ceiling is not sufficient for a correct installation and energy supply passage, in this case a trim of 150mm in height can be ordered (optional) as shown in the lower right part of figure 6.

- Cut the threaded bolts M16 x 350 mm (3) to length if necessary.
- The ceiling trim (3) will be fitted flush with the false ceiling at a later date. It covers the counter plate (4). See figure 14.
- If the threaded bolts M16 x 350 mm (3) have been cut, remove the burrs to ensure maximum thread engagement in the interface plate (1).



Fit 1 spring washer (1) and screw 1 M16 hex nut (2) each onto the M16 threaded bolts (3).

If the M16 threaded bolts (3) (3) are not completely screwed in, they may come out of the interface plate (1) and cause the system to fall down.

- Check that the shortened M16 threaded bolts (3) are securely fastened at the correct distance from each other and fully screwed into the interface plate 1.



M16 hexagon nuts (2) must be tightened to 195 Nm

6.5. Mounting the downpipe on the interface plate

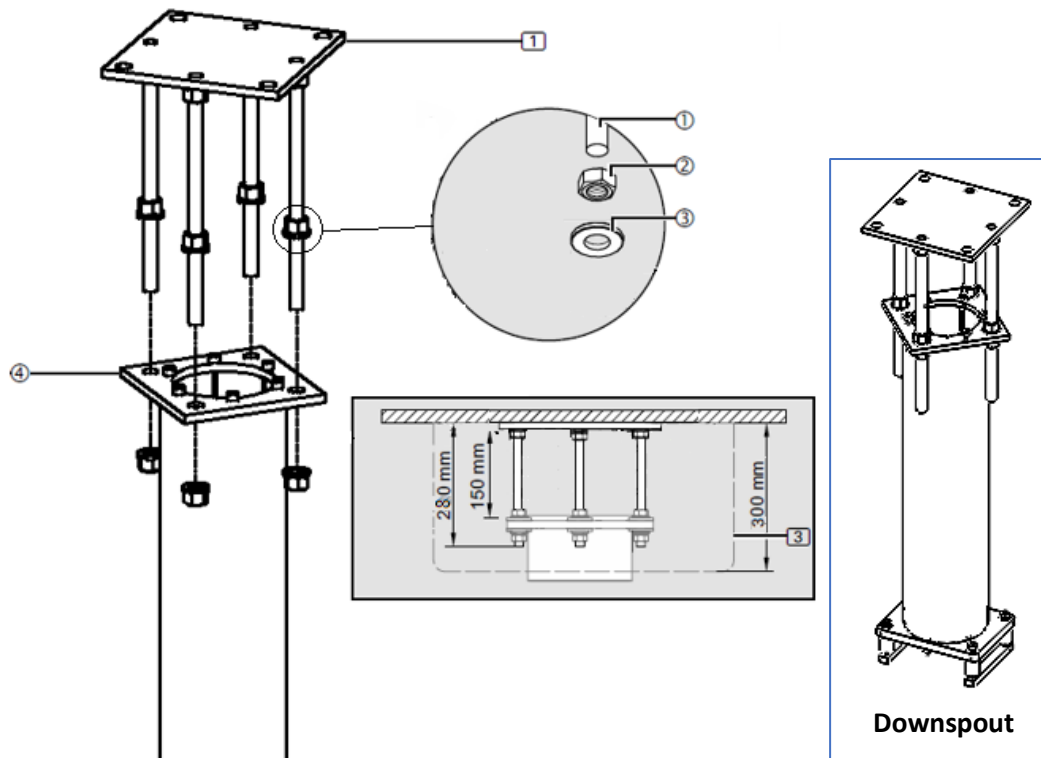

Fig. 7 Mounting of the downpipe on the interface plate

- For each M16 threaded bolt (1) screw on an M16 hexagon nut (2).

The M16 hex nuts (2) must be mounted on the M16 threaded bolts (1) at exactly the right distance from each other.

- Adjust the distance between the M16 hex nuts (2) and the interface plate from 1 to 150mm.
- Using a digital spirit level, align the M16 hex nuts (2) horizontally.
- Fit 1 flat washer with an outer diameter of 34 mm (3).
- Secure the flat washer (3) with adhesive or elastic tape on the threaded bolts (1).
- Fit the downpipe by passing the threaded bolts through the 16.5 mm holes in the counter plate (4).
- Fit a flat washer with an outer diameter of 34 mm (3).
- For each M16 threaded bolt (1) screw on an M16 hexagon nut (2) to secure the downpipe.

6.6. Disassembly and assembly of covers

The main body of the ATLAS is supplied finished, so for on-site installation, the side walls and top covers must be removed in order to be able to connect to the downpipes and, if necessary, to fit other accessory equipment (trolleys).

6.6.1. Disassembly and assembly of upper decks

- Using a flat-nosed tool and taking care not to damage the paint on the top covers, remove the bottom covers of the downpipes ①, these are press-fitted. See figure 8.
- Now move the upper covers of the main body ②, which are also press-fitted, by hand, first in the direction of the main body and, once the side wall has been cleared, by pulling them upwards. See figure 8.

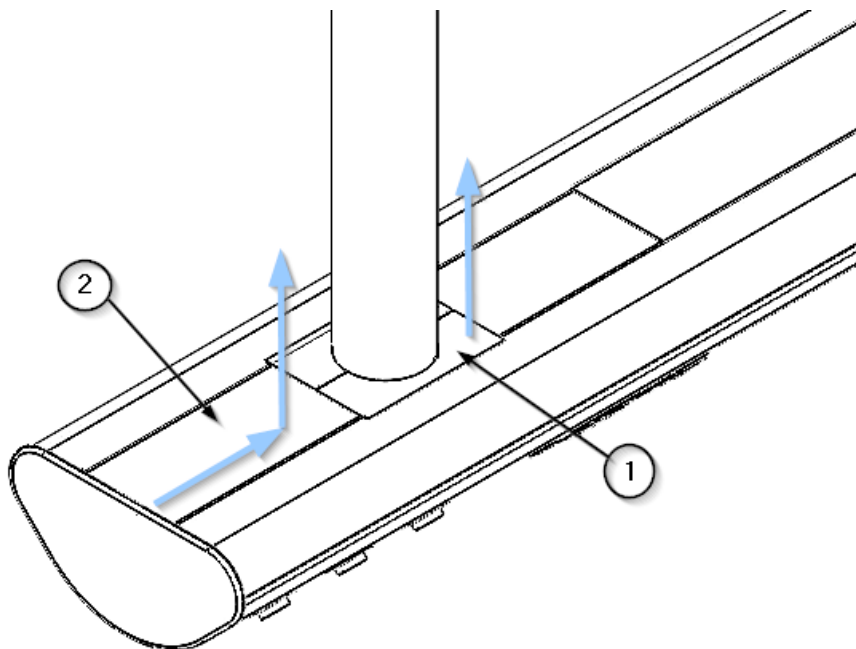

Fig. 8 Removal of main body covers

- To reassemble these covers, carry out the above steps in reverse order.
- First attach the top covers ②. You will hear a sound when the clipping is done, slide it until it makes contact with the side wall. Check that the covers are securely fastened.
- Then fit the lower downpipe covers ① by applying pressure until you hear them click into place. Check that they are properly secured.

6.6.2. Disassembly and assembly of side walls

- Remove the top cover from the main body as described in section 6.6.1 of this manual.

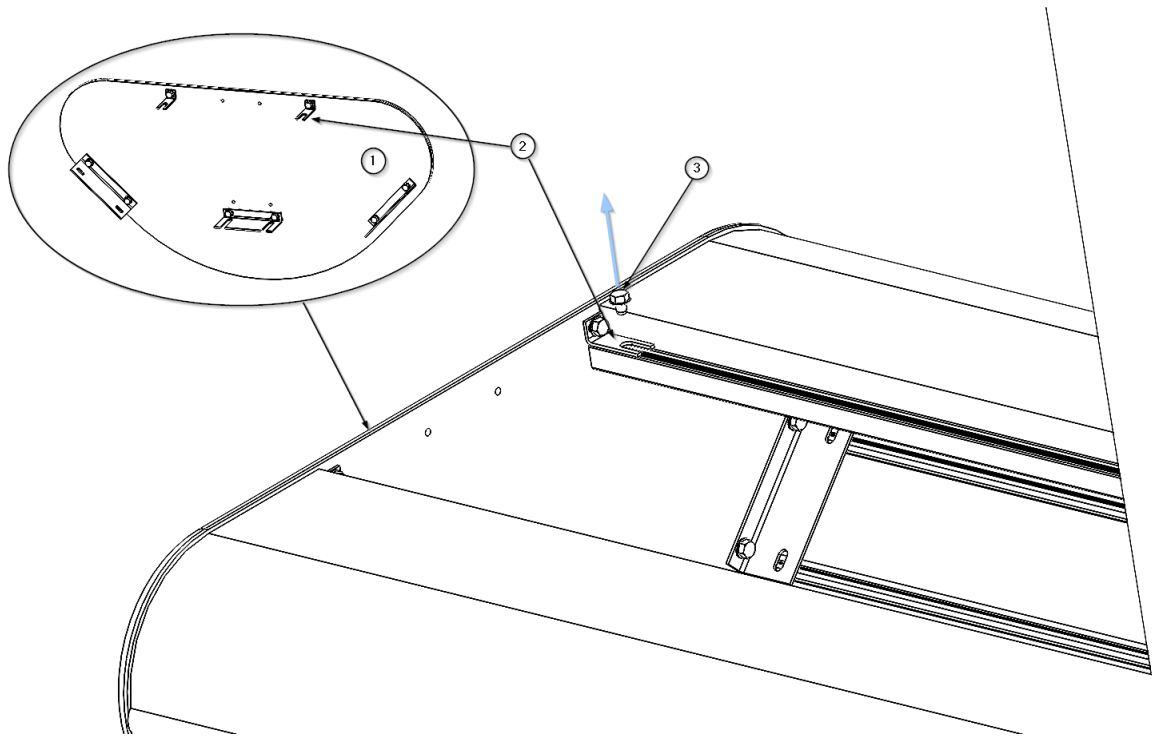

Fig. 9 Disassembly/assembly of end caps on ATLAS main body

- Using a hexagonal tool, remove the 8 M4 x 6 screws (3) securing the 5 side flanges (2) of the side wall (1), as shown in figure 9.
- Carefully remove the side panel (1) and place it in a safe place.
- To reassemble the end caps, carry out the above steps in reverse order.
- First attach the end cap (1) by supporting the side tabs (2) in the threaded slots of the main body and secure it with the 8 M4 x 6 screws (3).
- Check that the side wall (1) is properly fixed.

6.7. Installation of a section of the main body on two downpipes

Inside each suspended head section (main body) there are spacers (1), M8 x 80mm threaded bolts (2), M8 hex nuts (3), S10 lock washers (4) and platens (5), which are required for fastening to the downpipes. See figure 13.

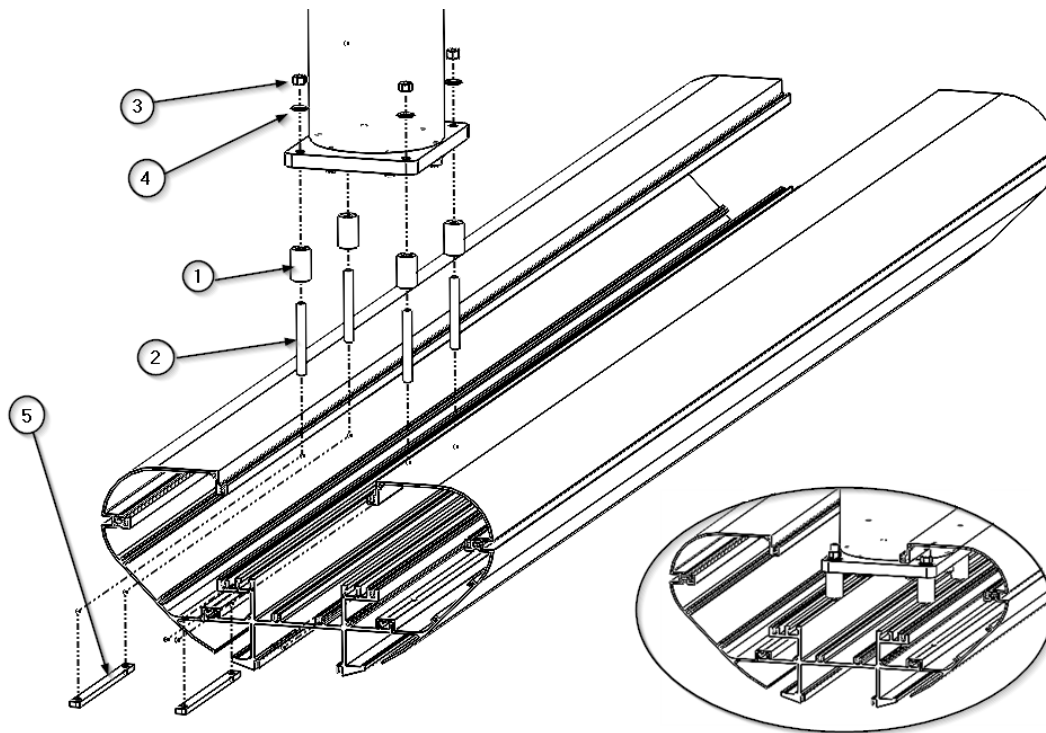

Fig. 10 Anchoring diagram of an ATLAS main body section on a downpipe

- Remove the lower downpipe covers and, if necessary, the upper main body covers as described in section 6.6.1 of this manual.
- Remove the M8 hex nuts (3) (3) and S10 lock washers (4) and store them in a safe place.
- Fit the threaded bolts (2) and use them to anchor the suspension chassis to the downpipe as shown in the picture on the left in figure 15, but do not tighten them completely.
- Make sure that the equipment is aligned and level. Then tighten the M8 nuts (3) (3) of all downpipes to a torque of 40 Nm.



The M8 hex nuts (3) must be tightened to 40 Nm.

- Finally, fit the previously removed covers to the main body following the steps described in section 6.6.1 of this manual.

6.8. Assembly of a trolley

This section shows the assembly of a trolley. This element does not come pre-assembled, it must be installed once the main body has been installed in the room where it is to be used.

- Remove the side wall as described in section 6.6.1 of this manual.
- Position the first carriage limit switch (the one furthest from the head end) as described in section 6.10.2 of this manual.

- Insert the carriage with the bearings ② into the guide in the centre of the main body ① as shown in figure 14.

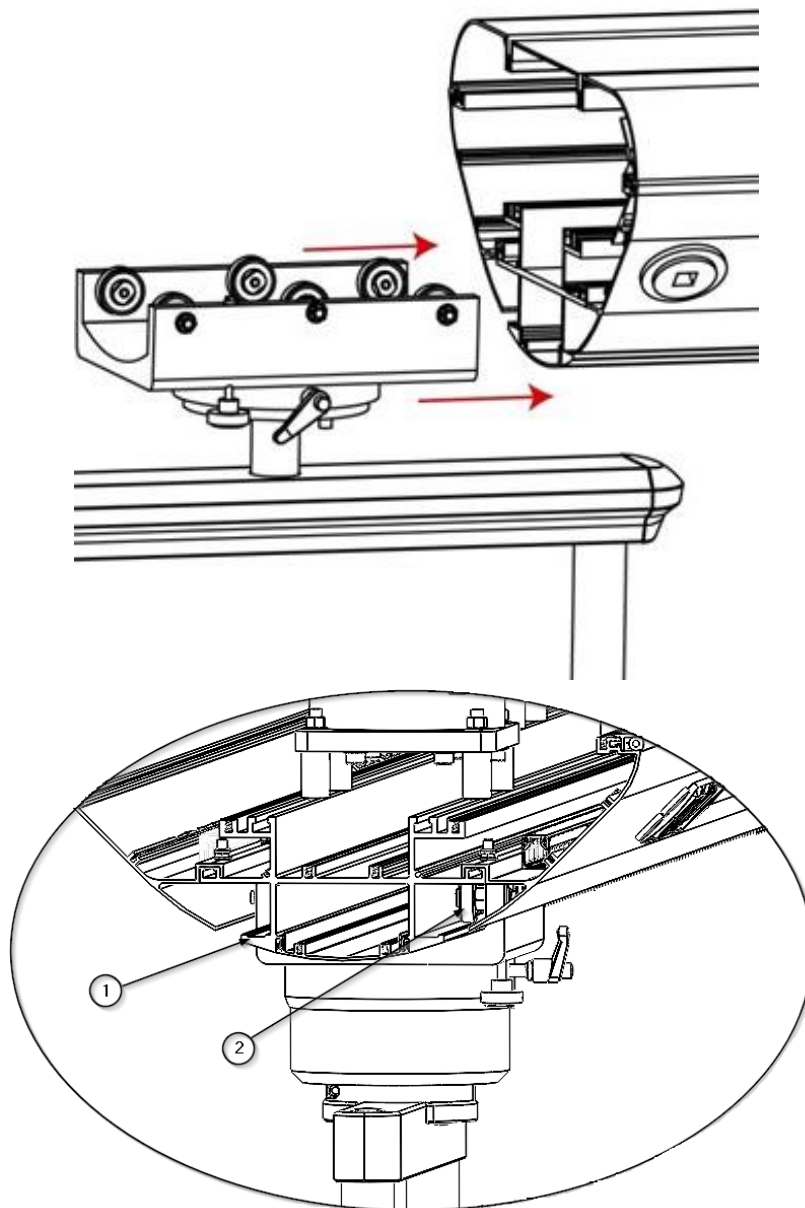

Fig. 11 Assembly of the trolley

- Fit the second limit switch as described in section 6.10.2 of this manual.
- Refit the side wall as described in section 6.6.2 of this manual.

6.9. Cable / Pipe entry



Before any installation and adjustment work, the pendant system must be disconnected from the mains.

6.9.1. Preparation of supply lines

In order to install the main body of the equipment, the supply lines to the equipment, which have previously been passed through the downpipes, must be prepared.

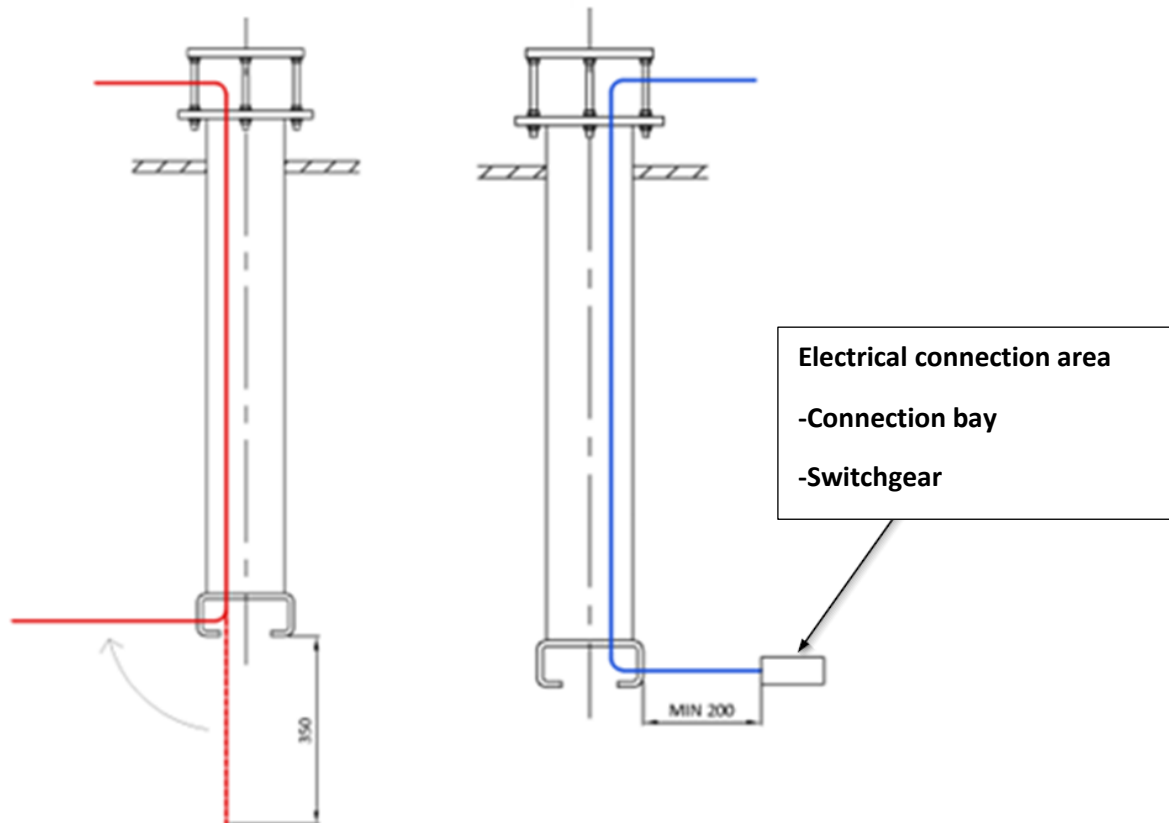

Fig. 12 Preparation of supply lines

In order to be able to work comfortably, the copper pipes should protrude about 350mm below the downpipe. At this point they should be bent in such a way that they are horizontal and above the lower face of the lower anchor of the downpipe. See picture on the left in figure 15.

The electrical cables should protrude about 200 mm from the bottom of the downpipe to ensure that the connection area (where the terminal block is located) can be reached without any problems. See picture on the right in figure 15.

Damaged power cables can carry 230 V electrical voltage that energises the pendant system, and supply gases can escape from damaged supply hoses:

- Check all cables and hoses for damage. Be sure to insert them carefully without the cables/hoses crossing each other, without loops and without kinks.
- Cables and pipes must be positioned in the suspension system in such a way that they are not exposed to tensile stresses.

- Cables and copper pipes should be routed straight up out of the flange to prevent damage (e.g. chafing of the sheathing) and to allow free rotation.
- Protruding cables must not be routed in the service head or flanges, but must be routed in the interface plate and secured against dropping with cable retainers.
- Electrical cables should be routed according to regional standards (in a spiral coiled tube if necessary).

Power and earthing cables as well as gas pipes are pre-installed in the service head and run through the pendant system. Order-specific cables, including telephone and nurse call cables, must be routed separately through the pendant system.

6.9.2. Gas piping and anaesthetic gas evacuation installation

To connect the gas circuits, remove the top cover of the main body.



See section 6.6.1 of this manual.

- Ensure that gas types are correctly assigned

The gas type is indicated by colour on the gas supply tubes. These tubes are fitted with a sealing plug which can only be removed during installation.

- Check the pipes and ducts for dirt and clean them with oil-free air.
- Ensure that cables, hoses and conduits are assigned to the correct supply outlets.

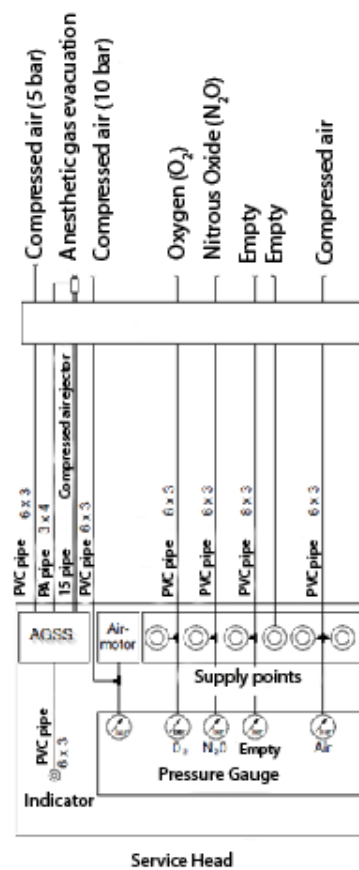

Fig. 13 Example of connection of gas lines and anaesthesia gas evacuation systems

- Prepare the copper connections for each gas outlet.
- The gas connection is made in the central body of the ATLAS.
- Check the diameter of the gas connections, which must be duly indicated, together with the type of gases (oxygen, vacuum, air, etc.).
- Perform the welding of each of the compressed medical gas and vacuum supply circuits according to EN ISO 9170-1 and anaesthetic gas evacuation systems according to EN ISO 9170-2.
- Perform a gas type test by following these 5 points:
 1. Gas outlets and marking according to EN ISO 9170-1 or EN ISO 9170-2
 2. Leakage according to EN ISO 11197
 3. Congestion according to EN ISO 7396-1 or EN ISO 7396-2
 4. Solid contamination according to EN ISO 7396-1 or EN ISO 7396-2
 5. Gas type according to EN ISO 7396-1 or EN ISO 7396-2

6.9.3. Connection of the different electrical circuits

To connect the electrical circuits, remove the top cover of the main body.



See section 6.6.1 of this manual.

The electrical connection is always made in the connection area shown in figure 15. This is located on the main body, next to one of the downpipes. All electrical hoses are numbered to identify the circuit to which they belong. The colour of the cable will indicate whether it is an earth connector, a neutral or a phase.



Before any installation and adjustment work, the pendant system must be disconnected from the mains.

- Cut all green/yellow earthing wires (2.5 mm² and 10 mm²) to the correct length.
- Connect them to the 2.5 mm² or 10 mm² series terminals on the earth terminal block provided in the connection area.
- All earthing cables must be securely installed in the strain relief mechanisms.
- Connect the power wires to the terminal block as illustrated in the wiring diagram supplied with the equipment.



See installation drawing(s) accompanying the equipment.

- All power cables must be securely installed in the strain relief mechanisms.
- Carefully check that the power cables are not trapped or kinked during the entire translation and rotational movement of the service heads.

6.10. Limit switch adjustment for element carriages

ATLAS equipment trolleys can slide freely along the entire length of the main body section on which they are installed. It is necessary to limit their travel to ensure that they do not conflict with patient and operator space. See figure 22 and 23.

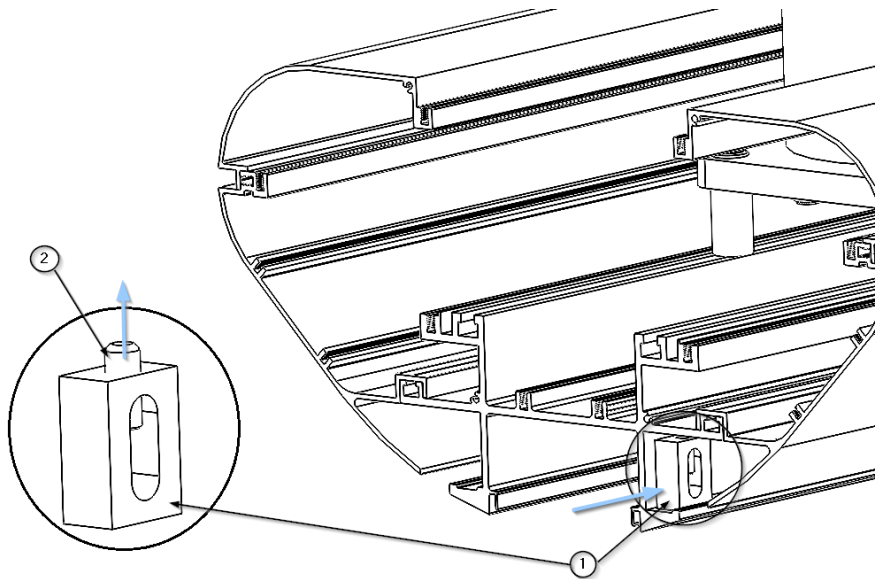

Fig.14 Adjusting the travel limit switches.

- Use an Allen key to loosen the bolt (2) of the cross stop (1).
- Move the cross stop to the desired position on the Atlas main body guide.

The example in figure 23 shows an ATLAS unit with two element carriages, the limit switches must ensure that the element carriages do not collide with the other elements in the environment.

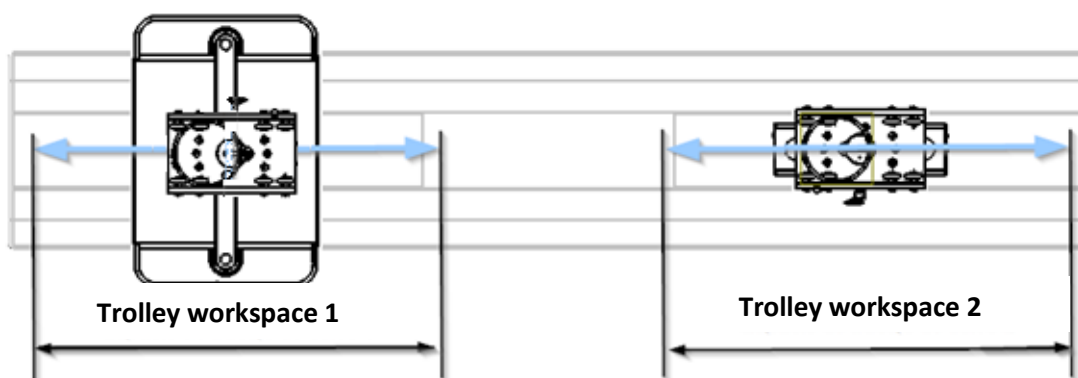

Fig.15 Adjusting the travel limit switches. Maximum stroke

- Tighten the Allen stud (2) and check that the cross stop is fixed in this position.
- Do the same with the second crosscut fence.



The hexagon socket bolts (2) M8 - DIN 913 must be tightened to 40 Nm.

7. Installation checks

When making adjustments to the equipment, it is necessary:

- verify that the relevant medical gas shut-off valves are properly closed and ensure that the system cannot be reopened.
- verify that the system is electrically disconnected, and measures must be taken to ensure that the system cannot be reconnected.



CAUTION: Failure to comply with this point will cause serious damage.



Before any installation and adjustment work, the pendant system must be disconnected from the mains.

7.1. Check the technical characteristics of the equipment.

Before proceeding with the installation of the equipment, it must be checked that the surface on which the equipment is to be installed meets the space and resistance requirements according to the characteristics of the equipment in question.



See point 6 of the user and cleaning manual supplied with the equipment.

7.2. Mechanical test

It must be checked that each of the anchorage points is properly fixed to the mounting surface and that there is no displacement of the equipment.



Personal injury may result from falling equipment



See section 6.4 of this manual

7.3. Mechanical crash test

Once the system has been installed, it must be checked to ensure that no collisions can occur with:

- other hanging systems,
- ceilings or walls,
- other equipment

If it is necessary to adjust the stroke of the trolleys.



See section 6.10 of this manual

7.4. Gas circuit test.

The equipment must be tested according to the current standards, EN ISO 7396-1_2016 and EN ISO 7396-2_2007 by qualified personnel.

The medical gas piping system shall be checked:

- Watertightness
- Integrity
- No crossovers between circuits.
- Good functioning of the gas intakes

These tests shall be carried out at operating pressure.



CAUTION: Danger of metallic element impact due to faulty disconnection, can cause serious personal injury.

7.5. Electrical circuit tests.

Once the equipment has been installed, power must be supplied to each of the circuits provided and a test must be carried out to check that all the mechanisms provided in the circuit in question, and only these, are supplied with voltage.

- Check continuity of protective earth wiring.



DANGEROUS VOLTAGE: To avoid risk of electric shock, equipment must be connected to a protective earth. Failure to do so may result in personal injury.



See manufacturing drawing(s) accompanying the equipment.

8. Regulations

8.1. Team ranking

According to the new **MDD** regulation **93/42/EEC** concerning medical devices, this product family is classified as:

- Class IIb, by Annex II, excluding section 4, regulation 11.
- Protection level IP20 according to IEC 60529.

Equipment intended for continuous operation.

8.2. Reference standards

The device complies with the safety requirements of the following standards and directives:

ISO11197: Medical supply units.

IEC 60601-1: Medical electrical equipment. General requirements for basic safety and essential performance.

IEC 60601-1-2: Medical electrical equipment. Part 1-2. General requirements for basic safety and essential performance. Collateral standard. Electromagnetic disturbances.